

Technical Manual

MC 5004

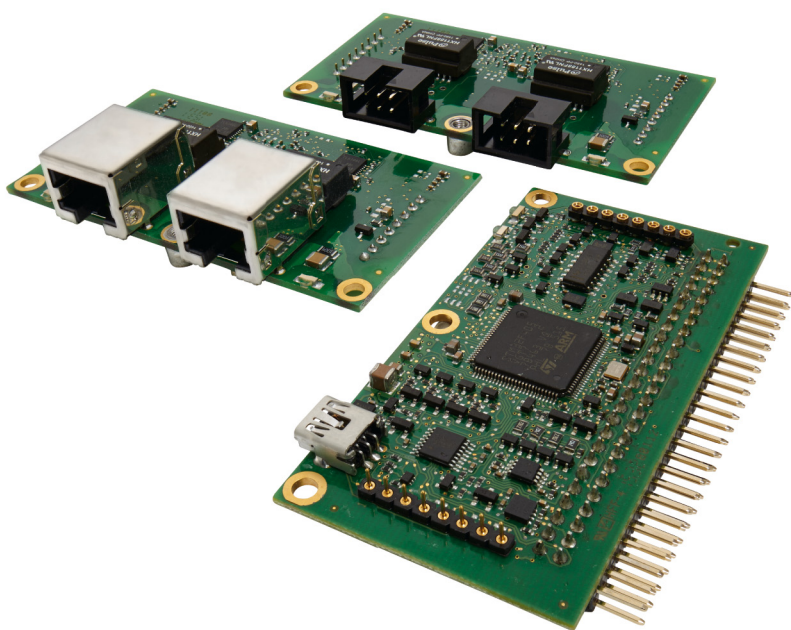

Imprint

Version:
6th edition, 22.05.2023

Copyright
by Dr. Fritz Faulhaber GmbH & Co. KG
Faulhaberstraße 1 · 71101 Schönaich

All rights reserved, including those to the translation.
No part of this description may be duplicated, reproduced,
stored in an information system or processed or
transferred in any other form without prior express written
permission of Dr. Fritz Faulhaber GmbH & Co. KG.

This document has been prepared with care.
Dr. Fritz Faulhaber GmbH & Co. KG cannot accept any
liability for any errors in this document or for the
consequences of such errors. Equally, no liability can be
accepted for direct or consequential damages resulting
from improper use of the equipment.

The relevant regulations regarding safety engineering
and interference suppression as well as the requirements
specified in this document are to be noted and followed
when using the software.

Subject to change without notice.

The respective current version of this technical manual is
available on FAULHABER's internet site:
www.faulhaber.com

Content

1	About this document	5
1.1	Validity of this document	5
1.2	Associated documents	5
1.3	Using this document	5
1.4	List of abbreviations	6
1.5	Symbols and designations	7
2	Safety	8
2.1	Intended use	8
2.2	Safety instructions	9
2.2.1	Dangers in the event of damages and changes	9
2.2.2	Correct installation and commissioning	9
2.2.3	Heat development	10
2.3	Environmental conditions	10
2.4	EC directives on product safety	11
3	Product description	12
3.1	General product description	12
3.2	Product information	13
3.3	Product variants	14
3.3.1	Controller PCBs	14
3.3.1.1	Standard PCB	14
3.3.1.2	PCB with vertical plug connector (option 5621)	15
3.3.1.3	EtherCAT PCB	16
3.3.2	Motherboard	17
4	Installation	21
4.1	Mounting	21
4.1.1	Mounting instructions	21
4.1.2	Installation of Motion Controller PCBs	22
4.2	Electrical connection	23
4.2.1	Notes on the electrical connection	23
4.2.2	Drive connections	24
4.2.3	Connection of the power supply	24
4.2.3.1	Power supply	25
4.2.4	Connector pin assignment	25
4.2.4.1	Pin assignment of the Motion Controller connector strip	25
4.2.4.2	Pin assignment of the motherboard (motor side)	27
4.2.4.3	Pin assignment of the motherboard (supply side)	32
4.2.5	Motherboard: connection at the motor side	34
4.2.6	I/O circuit diagrams	38
4.2.7	External circuit diagrams	39
4.3	Electromagnetic compatibility (EMC)	43
4.3.1	Considered systems	43
4.3.2	Functional earthing	45
4.3.3	Cable routing	46

Content

4.3.4	Shielding	47
4.3.4.1	Establishing the shield connection	48
4.3.4.2	Establishing shield connection with cable lug	49
4.3.5	Sensor and encoder interfaces	50
4.3.5.1	Analog sensors and analog Hall sensors	51
4.3.5.2	Incremental encoders / Digital Hall sensors / Digital sensors	51
4.3.5.3	Encoders with absolute interface	51
4.3.6	Using filters	52
4.3.6.1	Installing the Motion Controller PCB in the top-hat-rail housing	53
4.3.6.2	PWM filter (motor-side)	54
4.3.6.3	Emission-reducing, ferrite-based filters (motor side)	54
4.3.6.4	Input-side filters	54
4.3.6.5	Insulation resistance	54
4.3.6.6	Coiling ferrite ring	55
4.3.7	Error avoidance and troubleshooting	56
5	Maintenance and diagnostics	58
5.1	Maintenance tasks	58
5.2	Diagnosis	58
5.3	Troubleshooting	60
6	Accessories	61
7	Warranty	62
8	Additional documents	63
8.1	Declaration of Conformity	63
8.2	Declaration of Incorporation	65

About this document

1 About this document

1.1 Validity of this document

This document describes the installation and use of the MC 5004 series.

This document is intended for use by trained experts authorized to perform installation and electrical connection of the product.

All data in this document relate to the standard versions of the series listed above. Changes relating to customer-specific versions can be found in the corresponding data sheet.

1.2 Associated documents

For certain actions during commissioning and operation of FAULHABER products additional information from the following manuals is useful:

Manual	Description
Motion Manager 6	Operating instructions for FAULHABER Motion Manager PC software
Quick start guide	Description of the first steps for commissioning and operation of FAULHABER Motion Controllers
Drive functions	Description of the operating modes and functions of the drive
Accessories manual	Description of the accessories

These manuals can be downloaded in pdf format from the web page www.faulhaber.com/manuals.

1.3 Using this document

- ▶ Read the document carefully before undertaking configuration, in particular chapter "Safety".
- ▶ Retain the document throughout the entire working life of the product.
- ▶ Keep the document accessible to the operating and, if necessary, maintenance personnel at all times.
- ▶ Pass the document on to any subsequent owner or user of the product.

About this document

1.4 List of abbreviations

Abbreviation	Meaning
AC	Alternating Current
AES	Absolute encoder
AGND	Analog Ground
AnIn	Analog input
CAN	Controller Area Network
CAN_L	CAN-Low
CAN_H	CAN-High
CLK	Clock
$\overline{\text{CLK}}$	Clock with logically inverted signal
CS	Chip Select
$\overline{\text{CS}}$	Chip Select
Data	Data cable
$\overline{\text{Data}}$	Data cable with logically inverted signal
DigIn	Digital input
DigOut	Digital output
DIP	Dual In-Line Package
EFC	Electronics Filter Conformity
EFM	Electronics Filter Motor
EFS	Electronics Filter Supply
EMC	Electromagnetic compatibility
ESD	Electrostatic discharge
ET	EtherCAT (Ethernet for Control Automation Technology)
GND	Ground
I/O	Input/Output
LA	Status LED EtherCAT
MC	Motion Controller
Mot	Motor
n.c.	not connected
PWM	Pulse Width Modulation
RxD	Receive Data
SGND	Signal ground
TxD	Transmit data
U_{DD}	Power supply

About this document

1.5 Symbols and designations

 **DANGER!**

Danger with high level of risk: if not avoided, death or serious injury will result.

- ▶ Measures for avoidance

 **WARNING!**

Danger with medium level of risk: if not avoided, death or serious injury may result.

- ▶ Measures for avoidance

 **CAUTION!**

Danger with low level of risk: if not avoided, minor or moderate injury may result.

- ▶ Measures for avoidance

NOTICE!

Risk of damage.

- ▶ Measures for avoidance

 Instructions for understanding or optimizing the operational procedures

- ✓ Pre-requirement for a requested action

1. First step for a requested action

-  Result of a step

2. Second step of a requested action

-  Result of an action

- ▶ Request for a single-step action

2 Safety

2.1 Intended use

The Motion Controllers described here are designed for use as slaves for control and positioning tasks for the following motors:

- DC-Micromotors
- Linear DC-Servomotors
- Brushless DC-motors

The Motion Controller is suitable in particular for tasks in the following fields of application:

- Robotics
- Toolbuilding
- Automation technology
- Industrial equipment and special machine building
- Medical technology
- Laboratory technology

When using the Motion Controllers the following aspects should be observed:

- The Motion Controller contains electronic components and should be handled in accordance with the ESD regulations.
- Do **not** use the Motion Controller in environments where it will come into contact with water, chemicals and/or dust, **nor** in explosion hazard areas.
- The Motion Controller is **not** suitable for use in combination with stepper motors.
- The Motion Controller should be operated only within the limits specified in the data sheet.
- Please ask the manufacturer for information about use under individual special environmental conditions.

2.2 Safety instructions

In addition to the safety risks described in this technical manual, machine-specific dangers could arise that cannot be foreseen by the manufacturer of the Motion Controller (e.g., risk of injury from driven components). The manufacturer of the machine in which the Motion Controller is installed must perform a risk analysis in accordance with the regulations applicable to the machine and inform the end user of the residual risks.

2.2.1 Dangers in the event of damages and changes

Damage to the Motion Controller can impair its functions. A damaged Motion Controller can unexpectedly start, stop or jam. This can result in damage to other components and materials.

- ▶ Do **not** start up a drive system with a defective or damaged Motion Controller.
- ▶ Appropriately mark a defective or damaged Motion Controller.
- ▶ Do **not** replace defective or damaged components of the Motion Controller.
- ▶ Make no changes (modifications, repairs) to the Motion Controller.
- ▶ Have loose or defective connections immediately replaced by an electrician.
- ▶ After replacing a defective or damaged Motion Controller, test and document the correct function.

2.2.2 Correct installation and commissioning

Errors during the installation and commissioning of the Motion Controller could impair its function. An incorrectly installed Motion Controller can unexpectedly start, stop or jam. This can result in damage to other components and materials.

- ▶ Follow the instructions for installation and commissioning given in these installation instructions exactly.
- ▶ Only have work on electrical operating equipment performed by an electrician.
- ▶ During all work on the electrical equipment, observe the 5 safety rules:
 - a) Disconnect from power
 - b) Secure against being switched on again
 - c) Check that no voltage is present
 - d) Ground and short-circuit
 - e) Cover or block-off adjacent parts that are under voltage

Electrostatic discharges can damage the electronics.

- ▶ Store and transport the Motion Controller in suitable ESD packaging.
- ▶ Handle the Motion Controller in compliance with the ESD handling regulations (e.g. wear an ESD wristband, ground surrounding components).
- ▶ During installation, ensure that components in the surroundings cannot be electrostatically discharged.

Safety

Soiling, foreign bodies, humidity and mechanical influences can damage the electronics.

- ▶ Keep foreign objects away from the electronics.
- ▶ Install the Motion Controller in a housing that protects it from mechanical influences and is adapted to the ambient conditions (protection class determination).

Installation and connection work whilst supply voltage is applied at the device can damage the electronics.

- ▶ Do **not** insert or withdraw connectors whilst supply voltage is applied at the Motion Controller.
- ▶ During all aspects of installation and connection work on the Motion Controller, switch off the power supply.

Incorrect connection of the pins can damage the electronic components.

- ▶ Connect the wires as shown in the connection assignment.

2.2.3 Heat development

Active components may cause the Motion Controller to heat up. If touched, there is a risk of burning.

- ▶ Protect the Motion Controller against being touched and cool sufficiently.
- ▶ If necessary, affix a suitable warning sign in the immediate vicinity of the controller.



Fig. 1: Suitable warning sign acc. to DIN EN ISO 7010

2.3 Environmental conditions

- ▶ Select the installation location so that clean dry air is available for cooling the Motion Controller.
- ▶ Select the installation location so that the air has unobstructed access to flow around the drive.
- ▶ When installed within housings and cabinets take particular care to ensure adequate cooling of the Motion Controller.
- ▶ Select a power supply that is within the defined tolerance range.
- ▶ Protect the Motion Controller against heavy deposits of dust, in particular metal dust and chemical pollutants.
- ▶ Protect the Motion Controller against humidity and wet.

2.4 EC directives on product safety

- ▶ The following EC directives on product safety must be observed.
- ▶ If the Motion Controller is being used outside the EU, international, national and regional directives must be also observed.

Machinery Directive (2006/42/EC)

The controllers with attached motor described in this technical manual may be drive systems according to the Machinery Directive. They are therefore to be considered incomplete machines according to the Machinery Directive. Compliance is documented by the Declaration of Incorporation for the product and by the EC Declaration of the Conformity.

EMC Directive (2014/30/EU)

The directive concerning electromagnetic compatibility (EMC) applies to all electrical and electronic devices, installations and systems sold to an end user. In addition, CE marking can be undertaken for built-in components according to the EMC Directive. Conformity with the directive is documented in the Declaration of Conformity.

Applied standards

Various harmonized standards were applied to the products described in this technical manual; these standards are documented in the EC Declaration of Conformity. You can find the Declaration of Incorporation for the product and the EC Declaration of Conformity in chap. 8, p. 63.

WEEE Directive (2012/19/EU)

The directive on the disposal of electrical and electronic devices prescribes the separate collection of old electrical and electronic devices. The products described in this technical manual fall within the scope of this directive.

3 Product description

3.1 General product description

The MC 5004 products are unboxed versions of the FAULHABER Motion Controllers and control either DC, LM or BL motors. The Motion Controllers are configured here via the FAULHABER Motion Manager softwareV6.

The drives can be operated in the network via the CANopen or EtherCAT fieldbus interface. In smaller setups, networking can also be performed via the RS232 interface. The Motion Controller operates in the network in principle as a slave; master functionality for actuating other axes is not provided. After basic commissioning via Motion Manager, the controllers can alternatively also be operated without communication interface.

The controllers can be plugged into a motherboard via the 50-pin connector strip. For this purpose, FAULHABER offers a motherboard for connecting up to four MC 5004 controllers.

With the integrated output stage with optimized current measurement, DC, BL and LM motors from the FAULHABER product line from 08 to 32 mm can be controlled.

The following connections are available on the connector strip:

- Communications interfaces
- Common or separate power supplies between motor and controller
- Various inputs and outputs
- Motor phases
- Feedback components such as:
 - Digital/analog Hall sensors
 - Incremental encoders with or without line drivers.

i Not all options of the BiSS-C interface are supported by FAULHABER Motion Controllers of the V3.0 series. Before using encoders from other manufacturers, clarify the compatibility with FAULHABER Support.

i Motion Controllers with RS232, CANopen or EtherCAT interface can also be operated independently of the communications interface if a pre-programmed function or sequence program has been programmed without digital command controls.

Product description

3.2 Product information

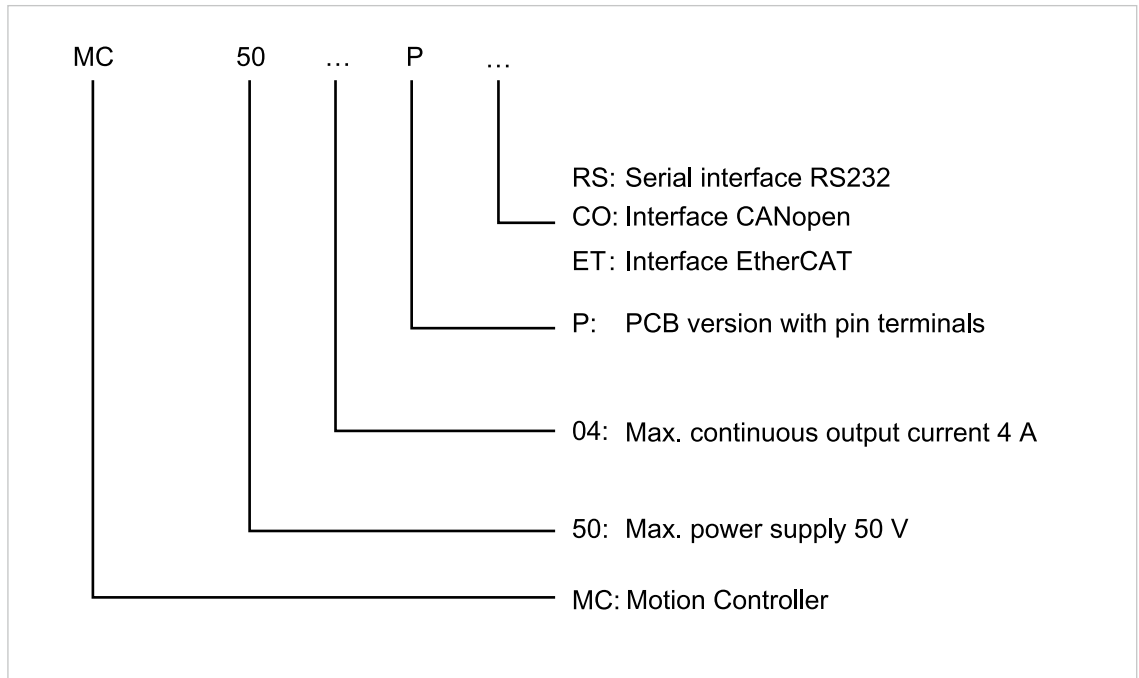

Fig. 2: Designation key

Product description

3.3 Product variants

The following product variants are possible:

- MC 5004 P RS/CO
- MC 5004 P ET

The Motion Controller PCBs can be mounted on a motherboard. The FAULHABER motherboard can accommodate up to four Motion Controller PCBs.

3.3.1 Controller PCBs

3.3.1.1 Standard PCB

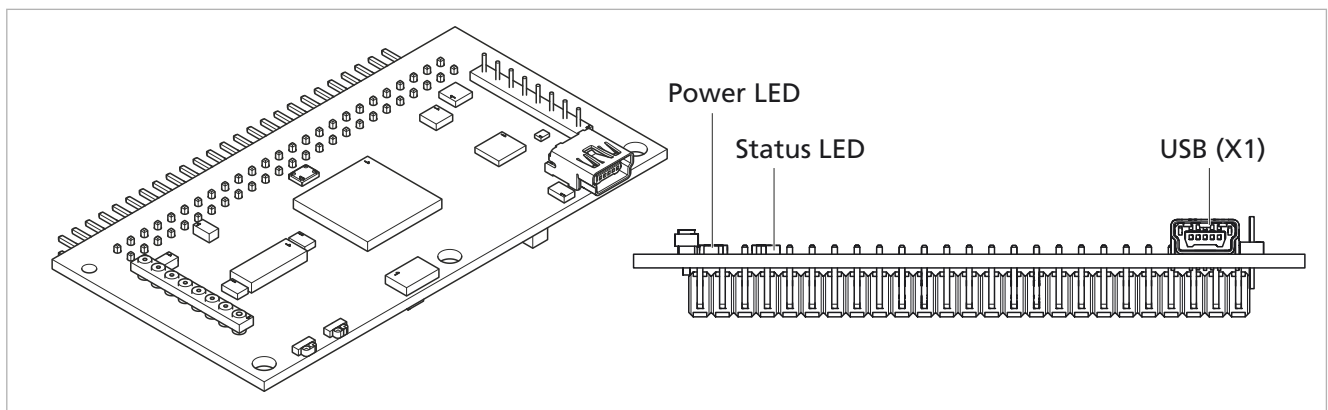

Fig. 3: Isometric (left) and front view (right) of the standard PCB

Tab. 1: Connector overview

Designation	Function
USB (X1)	Connection of the USB communication

Tab. 2: LED overview

Designation	Function
State LED	<ul style="list-style-type: none"> ■ Green (continuous light): Device active. ■ Green (flashing): Device active. However the state machine has not yet reached the <i>Operation Enabled</i> state. ■ Red (continuously flashing): The drive has switched to a fault state. The output stage will be switched off or has already been switched off. ■ Red (error code): Booting has failed. Please contact FAULHABER Support.
Power LED	<ul style="list-style-type: none"> ■ Green: Power supply within the permissible range. ■ Off: Power supply out of the permissible range.

Product description

3.3.1.2 PCB with vertical plug connector (option 5621)

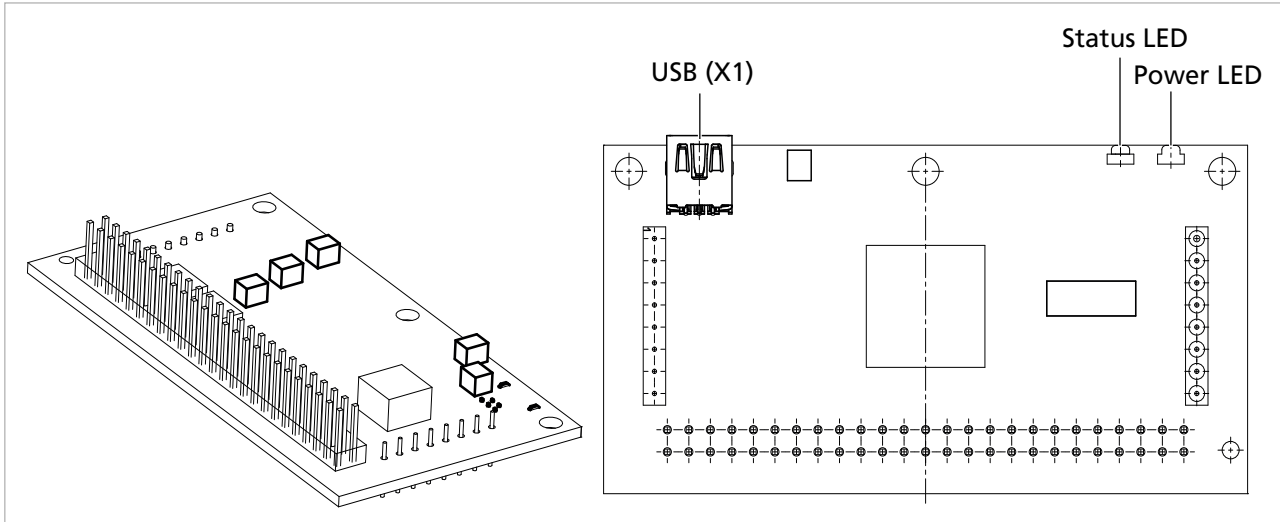

Fig. 4: Isometric view (left) and top view (right) of PCB with vertical plug connector

Tab. 3: Connector overview

Designation	Function
USB (X1)	Connection of the USB communication

Tab. 4: LED overview

Designation	Function
State LED	<ul style="list-style-type: none"> Green (continuous light): Device active. Green (flashing): Device active. However the state machine has not yet reached the <i>Operation Enabled</i> state. Red (continuously flashing): The drive has switched to a fault state. The output stage will be switched off or has already been switched off. Red (error code): Booting has failed. Please contact FAULHABER Support.
Power LED	<ul style="list-style-type: none"> Green: Power supply within the permissible range. Off: Power supply out of the permissible range.

Product description

3.3.1.3 EtherCAT PCB

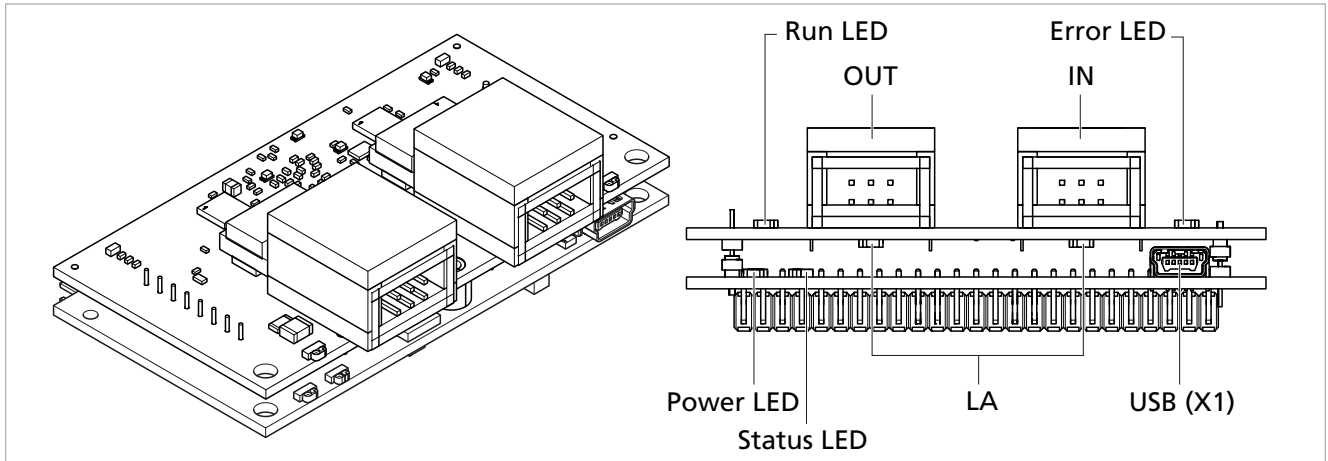

Fig. 5: Isometric (left) and front view (right) of the plugged-in EtherCAT PCB

Tab. 5: Connector overview

Designation	Function
IN/OUT	Connection of the EtherCAT communication
USB (X1)	Connection of the USB communication

Tab. 6: LED overview

Designation	Interface	Function
State LED	all	<ul style="list-style-type: none"> Green (continuous light): Device active. Green (flashing): Device active. However the state machine has not yet reached the <i>Operation Enabled</i> state. Red (continuously flashing): The drive has switched to a fault state. The output stage will be switched off or has already been switched off. Red (error code): Booting has failed. Please contact FAULHABER Support.
Power LED	all	<ul style="list-style-type: none"> Green: Power supply within the permissible range. Off: Power supply out of the permissible range.
RUN LED	EtherCAT	<ul style="list-style-type: none"> Green (continuous light): Connection present. Device is ready for use. Green (flashing): Device is in the <i>Pre-Operational</i> state Green (single flash): Device is in the <i>Safe-Operational</i> state Off: Device is in the <i>Initialisation</i> state.
ERR LED	EtherCAT	<ul style="list-style-type: none"> Red (flashing): Faulty configuration. Red (single flash): Local error. Red (double flash): Watchdog timeout. Off: No connection error
LA LED	EtherCAT	<ul style="list-style-type: none"> Green (continuous light): No data transfer. Connection to another participant established. Green (flashing): Data transfer active. Off: No data transfer. No connection to another participant.

Product description

3.3.2 Motherboard

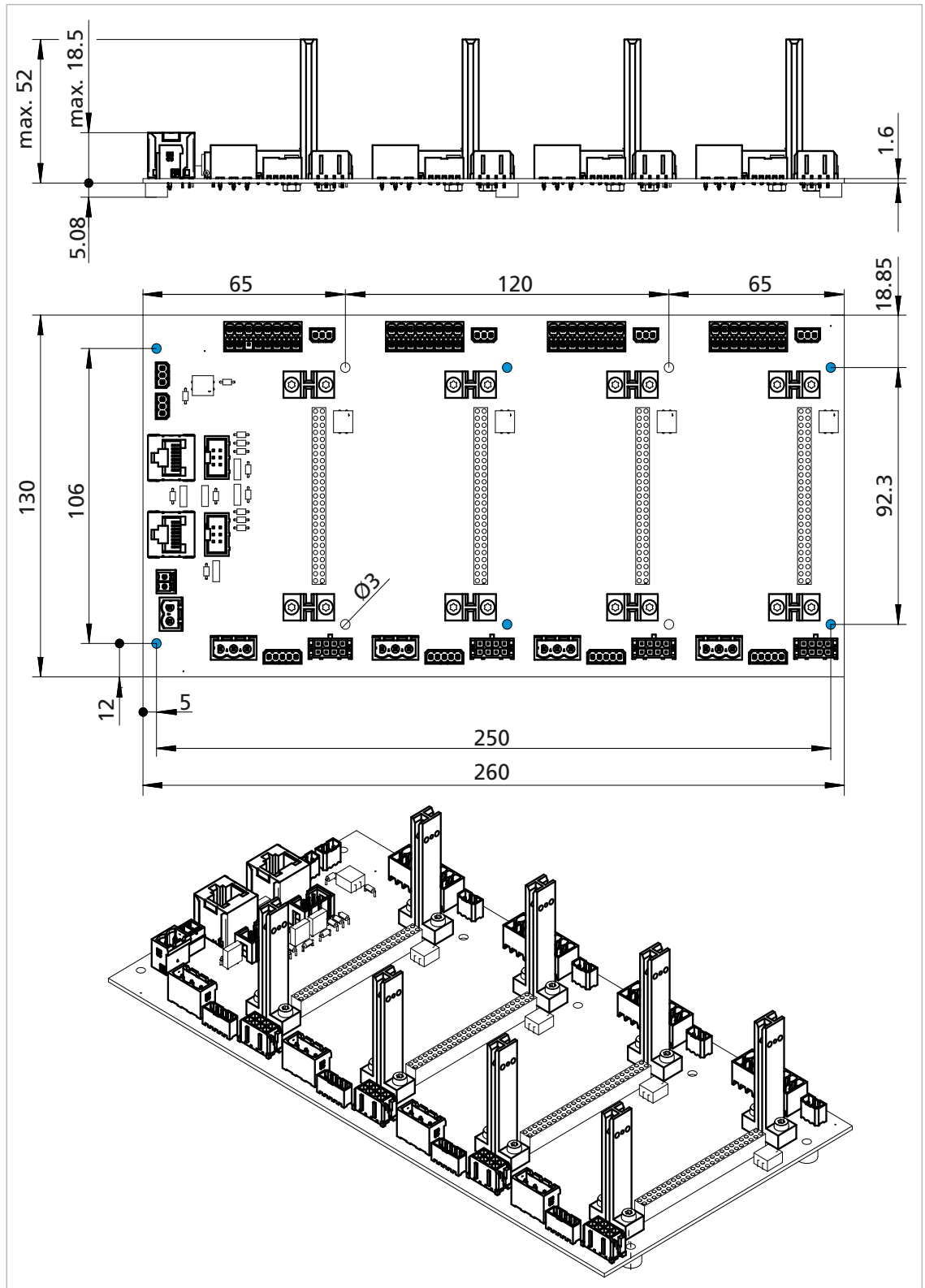

Fig. 6: Side view (top), top view (middle) and isometric view (bottom) of the motherboard with vertical connectors

Product description

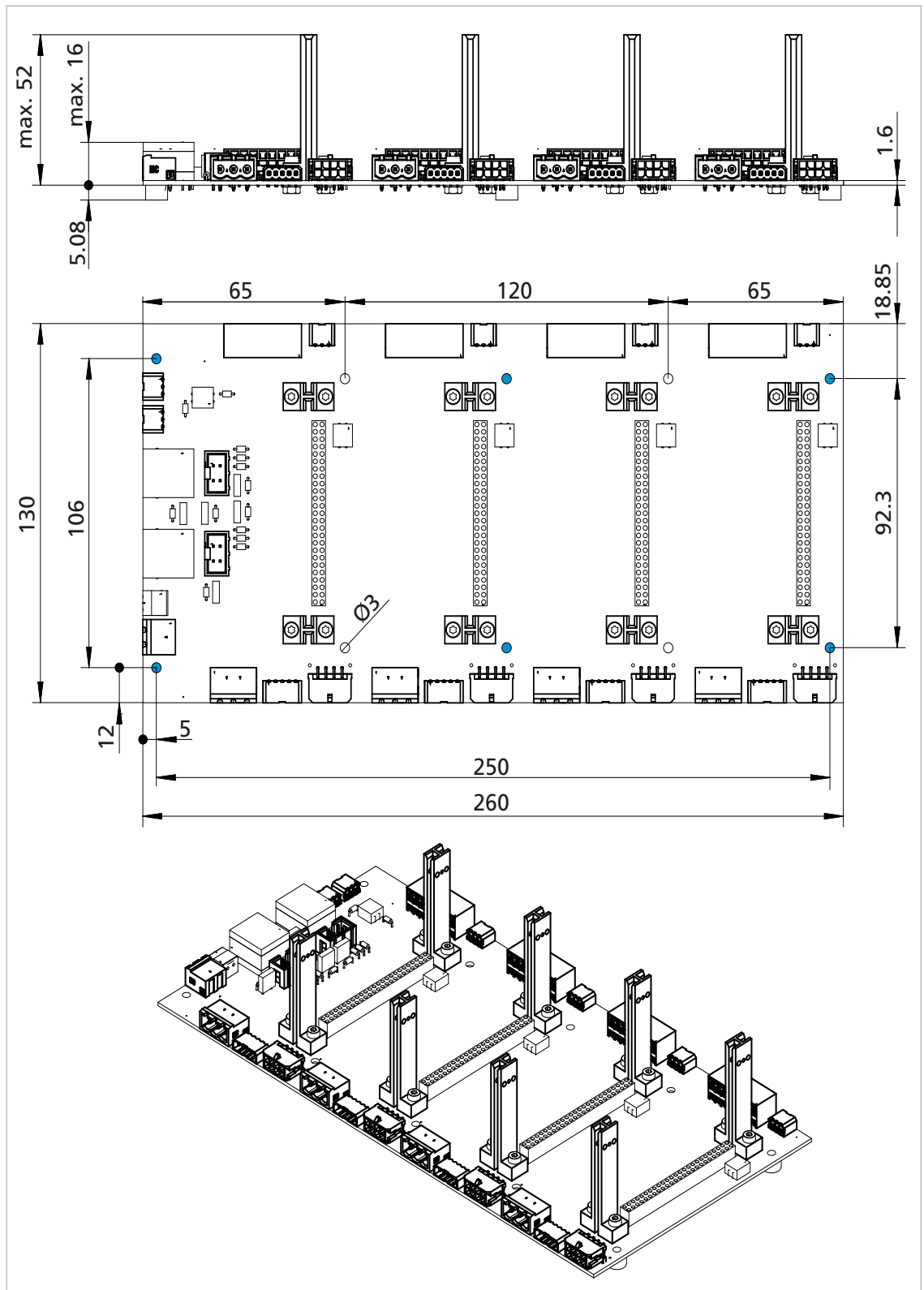

Fig. 7: Side view (top), top view (middle) and isometric view (bottom) of the motherboard with horizontal connectors

Product description

i On delivery, there are rubber pads in the outer and center holes of the motherboard. These holes are marked in blue in Fig. 6 and Fig. 7.

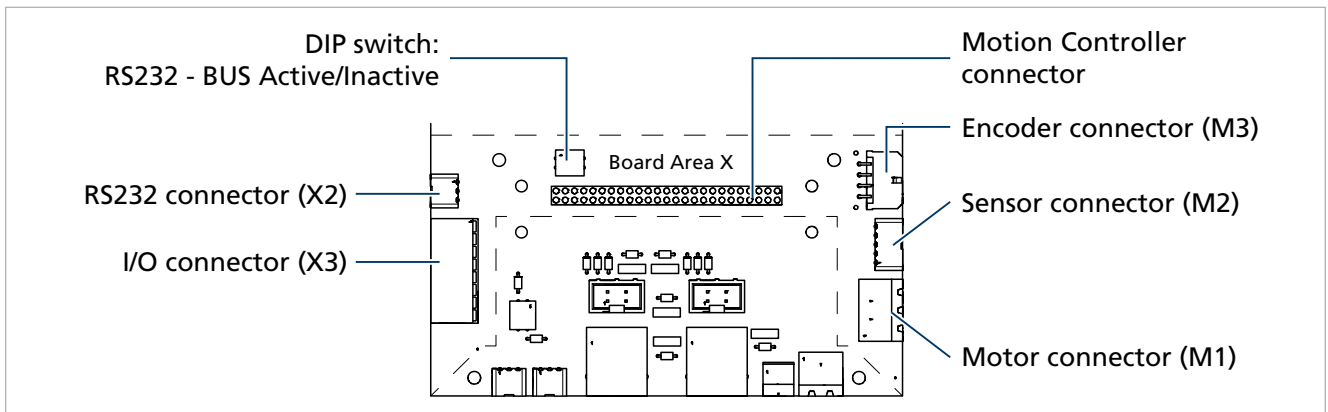

Fig. 8: Connector overview of the motherboard (board area)

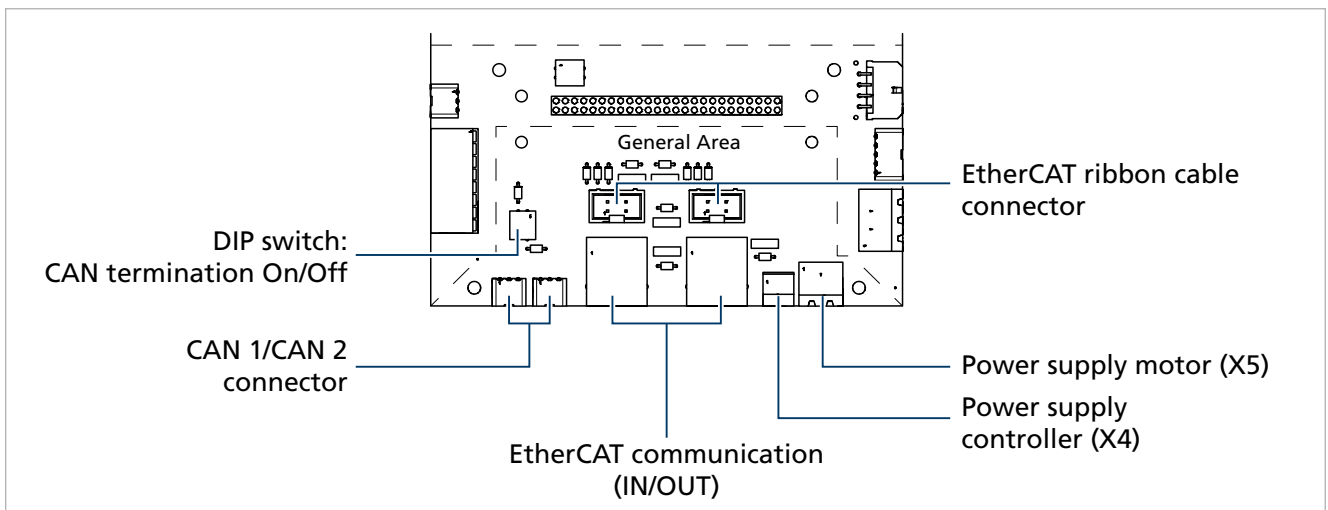

Fig. 9: Connector overview of the motherboard (general area)

Tab. 7: Connector overview of the motherboard

Designation	Function
Motion Controller connector	Connection of the Motion Controller PCB
M1 (motor)	Connection of the motor phases
M2 (sensor)	Connection of the Hall sensors
M3 (encoder)	Connection of an incremental encoder with or without line driver. Alternatively an absolute encoder can be connected with or without line driver.
X2 (COM)	RS232 interface connection
CAN 1/CAN 2	CANopen interface connection
X3 (I/O)	Inputs or outputs for external circuits
X4 (U_p)	Voltage supply of the controller
X5 (U_{mot})	Voltage supply of the motor
IN/OUT	Connection of the EtherCAT communication

Product description

Designation	Function
EtherCAT ribbon cable connector	Optional ribbon cable connection
DIP switch CAN termination	CAN termination resistor (On/Off): <ul style="list-style-type: none">▪ On: Termination resistor active▪ Off: Termination resistor inactive
DIP switch RS232 active/inactive	RS232 net mode (on/off): <ul style="list-style-type: none">▪ On: RS232 net mode active▪ Off: RS232 net mode inactive

4 Installation

Only trained experts and instructed persons with knowledge of the following fields may install and commission the Motion Controller:

- Automation technology
- Standards and regulations (such as the EMC Directive)
- Low Voltage Directive
- Machinery Directive
- VDE regulations (DIN VDE 0100)
- Accident prevention regulations

This description must be carefully read and observed before commissioning.

Also comply with the supplementary instructions for installation (see chap. 2.3, p. 10).

4.1 Mounting

4.1.1 Mounting instructions

CAUTION!

The Motion Controller can become very hot during operation.

- ▶ Place a guard against contact and warning notice in the immediate proximity of the controller (see chap. 2.2.3, p. 10).

DANGER!

Incorrect handling and installation can cause the Motion Controller to perform uncontrolled movements.

A damaged Motion Controller can unexpectedly start, stop or jam. Depending on the use of the Motion Controller, this can lead to severe or fatal injury.

- ▶ Observe the safety information in the chap. 2.2.1, p. 9.
- ▶ Use suitable fastening material (see the following chapter).

Visual inspection

- ▶ After unpacking the Motion Controller, perform and document a visual inspection:
 - Motion Controller is undamaged?
 - Sticker with serial number is present?
 - Pin contacts in the connectors are OK (not oxidized, not bent)?

DANGER!

The function of the Motion Controller is not ensured if the visual inspection criteria are not satisfied.

If the function is not ensured, the drive may start unexpectedly. Depending on the use of the Motion Controller, this can lead to severe or fatal injury.

- ▶ Do not start up the Motion Controller.

Installation

⚠ DANGER!

During operation, the drive system produces mechanical forces and movements.

- ▶ Protect the drive system and components driven by the drive system from being touched.

4.1.2 Installation of Motion Controller PCBs

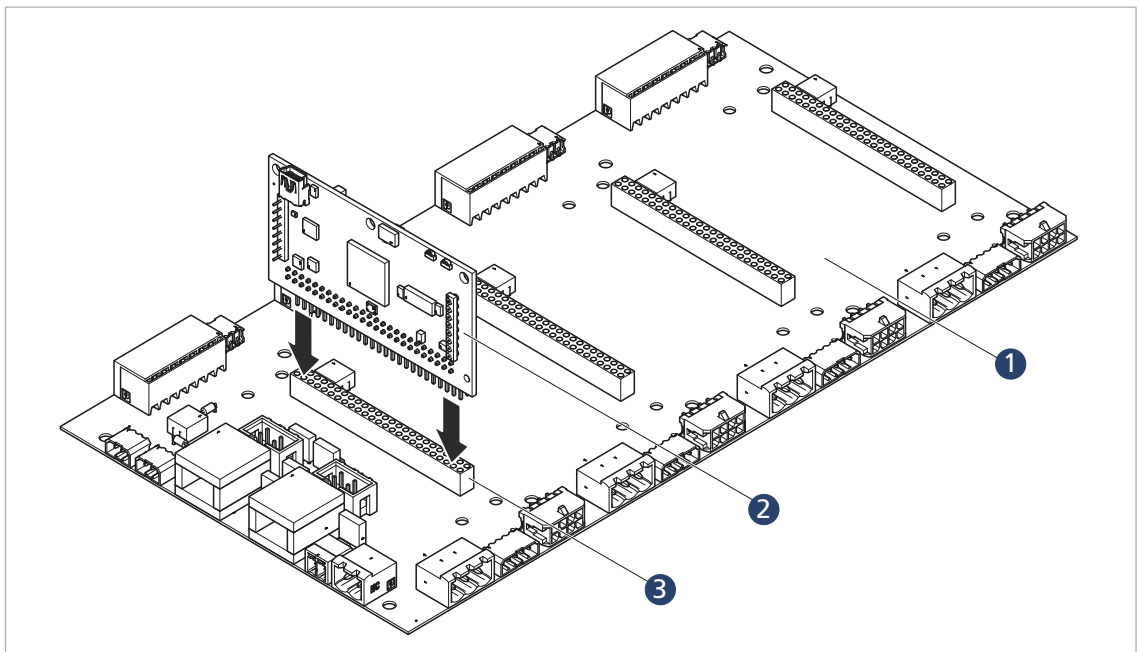

Fig. 10: Installation of a Motion Controller PCB

NOTICE!

Incorrect installation can damage the Motion Controller.

- ▶ Note orientation of the Motion Controller PCB acc. to Fig. 10.
- ▶ Connect the Motion Controller PCB (2) to the motherboard (1) using the plug connection (3).

Installation

4.2 Electrical connection

4.2.1 Notes on the electrical connection

NOTICE!

Electrostatic discharges to the Motion Controller connections can damage the electronic components.

- ▶ Observe the ESD protective measures.

NOTICE!

Incorrect connection of the wires can damage the electronic components.

- ▶ Connect the wires as shown in the connection assignment.

NOTICE!

A short-term voltage peak during braking can damage the power supply or other connected devices.

- ▶ For applications with high load inertia, the FAULHABER Braking Chopper of the BC 5004 series can be used to limit overvoltages and thereby protect the power supply. For more detailed information see the data sheet for the Braking Chopper.

The Motion Controller contains a PWM output stage for controlling the motors. Power losses arising during operation and alternating electrical fields arising due to the pulsed control of the motors, must be dissipated and damped by appropriate installation.

- ▶ Connect the Motion Controller to a grounding system. This should be done preferably by mounting it on an grounded baseplate, or alternatively by connecting it to an grounded mounting rail.
- ▶ Make sure that potential equalization is present between all coupled parts of the system. This applies even if the Motion Controller and motor are mounted separately.
- ▶ If several electrical devices or controllers are networked by means of RS232 or CAN, make sure that the potential difference between the ground potentials of the various parts of the system is less than 2 V.

↪ The cross-section of the required potential equalization conductors between the various parts of the system is specified in VDE 100 and must satisfy the following conditions:

- At least 6 mm²
- Larger than half the cross-section of the supply conductor

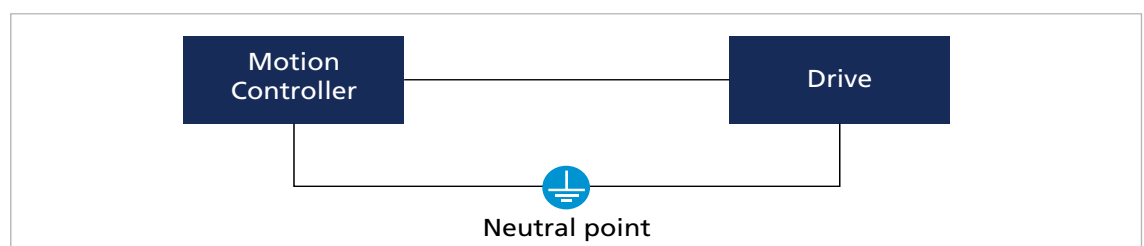

Fig. 11: Potential equalization between electrically connected parts of the system

Installation

4.2.2 Drive connections

The maximum length of the cable between the Motion Controller and motor depends on the sensor system used and the electrical and magnetic fields in the environment.

Tab. 8: Guide values for the cable length

Encoder type	Unshielded length	Shielded length ^{a)}
Digital Hall sensors	0.5 m	2–5 m
Analog Hall sensors	0.5 m	2–5 m
Incremental encoders without line driver	0.5 m	2–5 m
Incremental encoders with line driver	2 m	2–5 m ^{b)}
Absolute encoders without line driver	0.3 m	0.5 m
Absolute encoders with line driver	2 m	5 m ^{b)}

a) applies to cables separately shielded from the motor phase power cables.

b) For position encoders with Line Driver interface, the cables must be shielded, twisted pairs

Longer connection cables are generally permissible, but must be validated for the target installation.

Optimization of the behavior in respect of transient emission and interference resistance may require additional EMC measures (see chap. 4.3, p. 43).

4.2.3 Connection of the power supply

- Discrete inputs and outputs (for instance for discrete set-point specification or for connection of limit switches and reference switches)
- Communication connections
- ▶ Make sure that the connection cables on the connection side are not longer than 3 m.
- ▶ Keep the shield connections for connection cables short and flat.

i The USB port is a pure configuration connection. A cable length of < 3 m also applies for the USB connection.

To reduce the effects on the DC power supply network, ferrite sleeves (such as WE 742 700 790) can be used on the supply cables.

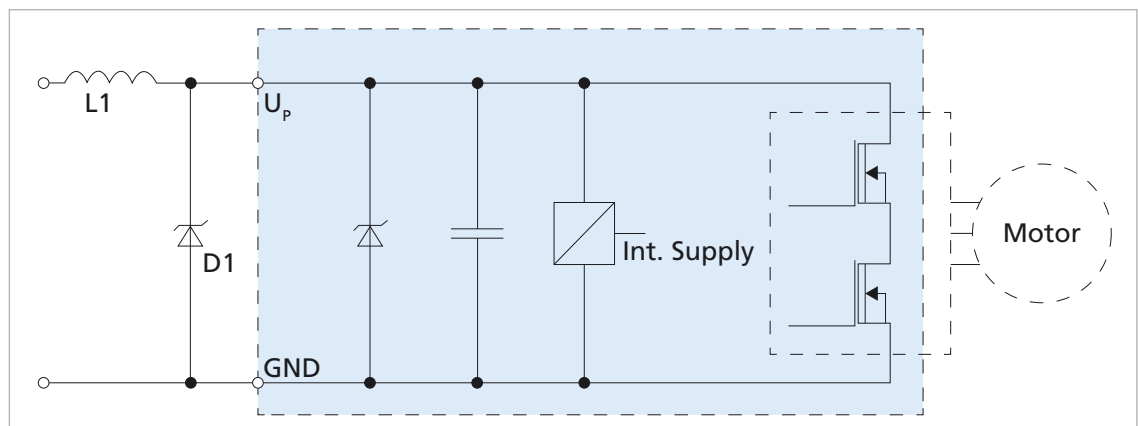

Fig. 12: EMC suppressor circuit

Installation

4.2.3.1 Power supply

- ▶ Connect the Motion Controller to a sufficiently dimensioned power supply unit.
- ▶ During acceleration procedures, current peaks with values up to the peak current limit setting of the motor can occur for multiples of 10 ms.
- ▶ During braking procedures, energy can be regenerated and fed back into the DC power supply network. If this energy cannot be taken up by other drives, the voltage in the DC power supply network will rise. A limit value for the voltage that can be fed back during regenerative braking can be set in the Motion Controller. Alternatively the over-voltage can be dissipated by an additional external brake chopper, see the data sheet for the brake chopper.

4.2.4 Connector pin assignment

4.2.4.1 Pin assignment of the Motion Controller connector strip

Motion Controllers have a connector strip by means of which the connection between Motion Controller and motherboard or customer-specific peripherals is established.

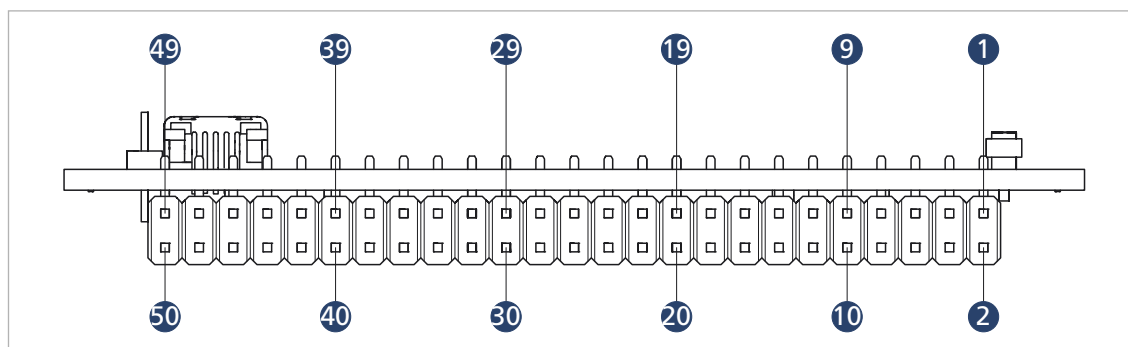

Fig. 13: Pin overview of the connector strip



For technical data, see motherboard pin assignment.

Tab. 9: Pin assignment of the connector strip

Pin	Designation	Meaning
1	Phase A	Motor phase A
2	Phase A	Motor phase A
3	Phase B	Motor phase B
4	Phase B	Motor phase B
5	Phase C	Motor phase C
6	Phase C	Motor phase C
7	U_{mot}	Power supply of the motor
8	U_{mot}	Power supply of the motor
9	GND	Ground connection
10	GND	Ground connection
11	U_p	Power supply of the electronics
12	n.c.	–
13	n.c.	–

Installation

Pin	Designation	Meaning
14	Sens A / SIN(+)	Hall sensor A / sine signal (sin/cos sensor)
15	Sens B / COS(+)	Hall sensor B / cosine signal (sin/cos sensor)
16	Sens C / n.c.	Hall sensor C / –
17	U _{DD}	Supply connection for sensors
18	GND	Ground connection
19	Channel A	Encoder channel A
20	$\overline{\text{Channel A}}$	Encoder channel A (logically inverted signal)
21	Channel B	Encoder channel B
22	$\overline{\text{Channel B}}$	Encoder channel B (logically inverted signal)
23	Index	Index channel
24	$\overline{\text{Index}}$	Index channel (logically inverted signal)
25	n.c.	–
26	n.c.	–
27	DigOut 1	Digital output
28	DigOut 2	Digital output
29	DigOut 3	Digital output
30	U _{DD}	Power supply for sensors
31	GND	Ground connection
32	DigIn 1	Digital input
33	DigIn 2	Digital input
34	DigIn 3	Digital input
35	DigIn 4	Digital input
36	DigIn 5	Digital input
37	DigIn 6	Digital input
38	DigIn 7	Digital input
39	DigIn 8	Digital input
40	AGND	Analog ground connection
41	AnIn 1	Analog input
42	AnIn 2	Analog input
43	n.c.	–
44	n.c.	–
45	n.c.	–
46	CAN-H	CAN-High interface
47	CAN-L	CAN-Low interface
48	GND	Ground connection
49	TxD	RS232 interface transmit direction
50	RxD	RS232 interface receive direction

Installation

4.2.4.2 Pin assignment of the motherboard (motor side)

Motor connection (M1)

Tab. 10: Pin assignment of the BL motor connection (M1)

Pin	Designation	Meaning
1	Motor A	Connection of motor, phase A
2	Motor B	Connection of motor, phase B
3	Motor C	Connection of motor, phase C

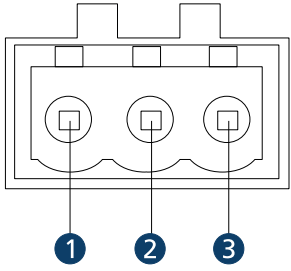

Tab. 11: Electrical data of the motor connection (M1)

Designation	Value
Motor power supply	0... U_{mot} Max. 4/12 A 100 kHz

Tab. 12: Pin assignment of the DC motor connection (M1)

Pin	Designation	Meaning
1	Motor +	Connection of motor, positive pole
2	Motor -	Connection of the motor, negative pole

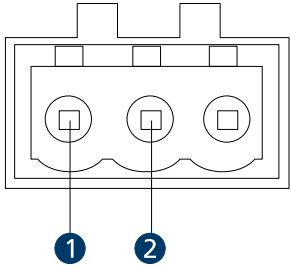

Tab. 13: Electrical data of the DC motor connection (M1)

Designation	Value
Motor power supply	0... U_{mot} Max. 4/12 A 100 kHz

Installation

Sensor connection (M2)

Tab. 14: Pin assignment of the sensor connection (M2)

Pin	Designation	Meaning
1	U _{DD}	Power supply for sensors
2	GND	Ground connection
3	Sens A	Hall sensor A
4	Sens B	Hall sensor B
5	Sens C	Hall sensor C

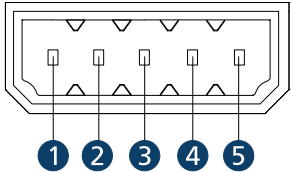

Tab. 15: Pin assignment at sensor connection (M2) for sin/cos sensor

Pin	Designation	Meaning
1	U _{DD}	Power supply for sensors
2	GND	Ground connection
3	COS(+)	Cosine signal
4	SIN(+)	Sine signal
5	n.c.	–

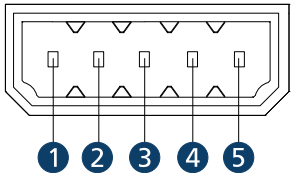

Only in combination with sin/cos sensors on FAULHABER LM motors or BX4 motors in sin/cos special version.

Tab. 16: Electrical data of the sensor connection (M2)

Designation	Value
Sensor power supply	5 V <100 mA
Sensor connection	<5 V

Installation

Encoder connection (M3)

The pin assignment of the encoder connector varies depending on the encoder type.

- Incremental encoder with or without line driver
- Absolute encoder with or without line driver.

Tab. 17: Pin assignment for incremental encoder with line driver (M3)

Pin	Designation	Meaning
1	U_{DD}	Power supply for incremental encoder
2	GND	Ground connection
3	$\overline{\text{Channel A}}$	Encoder channel A (logically inverted signal)
4	Channel A	Encoder channel A
5	$\overline{\text{Channel B}}$	Encoder channel B (logically inverted signal)
6	Channel B	Encoder channel B
7	$\overline{\text{Index}}$	Encoder index (logically inverted signal)
8	Index	Encoder index

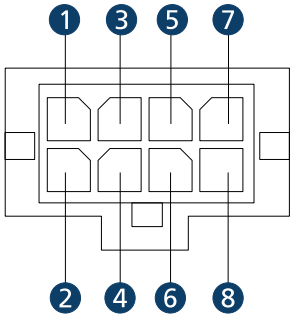

Tab. 18: Electrical data for incremental encoder with line driver (M3)

Designation	Value
Power supply for incremental encoder	5 V <100 mA
Connection of the incremental encoder	<5 V <2 MHz 5 k Ω

Tab. 19: Pin assignment for incremental encoder without line driver (M3)

Pin	Designation	Meaning
1	U_{DD}	Power supply for incremental encoder
2	GND	Ground connection
3	$\overline{\text{Channel A}}$	n.c.
4	Channel A	Encoder channel A
5	$\overline{\text{Channel B}}$	n.c.
6	Channel B	Encoder channel B
7	$\overline{\text{Index}}$	n.c.
8	Index	Encoder index

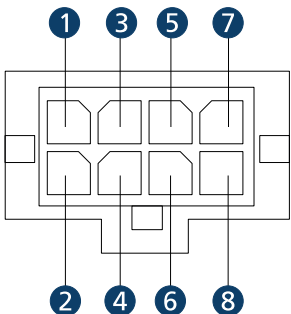

Installation

Tab. 20: Electrical data for incremental encoder without line driver (M3)

Designation	Value
Power supply for incremental encoder	5 V <100 mA
Connection of the incremental encoder	<5 V <2 MHz 5 k Ω

Tab. 21: Pin assignment for absolute encoder with line driver (M3)

Pin	Designation	Meaning
1	U_{DD}	Power supply for absolute encoder
2	GND	Ground connection
3	\overline{CS}	Chip Select for absolute encoder (logically inverted signal)
4	CS	Chip Select for absolute encoder
5	\overline{Data}	Data for absolute encoder (logically inverted signal)
6	Data	Data for absolute encoder
7	\overline{CLK}	Clock for absolute encoder (logically inverted signal)
8	CLK	Clock for absolute encoder

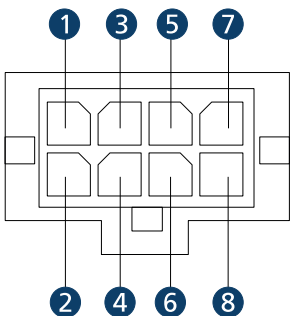

Tab. 22: Electrical data for absolute encoder with line driver (M3)

Designation	Value
Absolute encoder power supply	5 V <100 mA
Connection Chip Select	5 V
Connection data	<5 V 5 k Ω
Connection clock	5 V 1 MHz

Tab. 23: Pin assignment for absolute encoder without line driver (M3)

Pin	Designation	Meaning
1	U_{DD}	Power supply for absolute encoder
2	GND	Ground connection
3	\overline{CS}	n.c.
4	CS	Chip Select for AES
5	\overline{Data}	n.c.
6	Data	Data for AES
7	\overline{CLK}	n.c.
8	CLK	Clock for AES

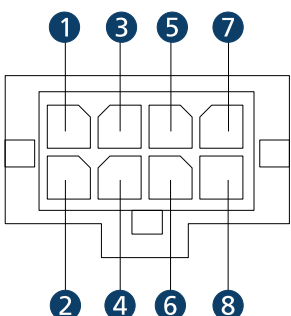

Installation

Tab. 24: Electrical data for absolute encoder without line driver (M3)

Designation	Value
Absolute encoder power supply	5 V <100 mA
Connection Chip Select	5 V
Connection data	<5 V 5 kΩ
Connection clock	5 V 1 MHz

COM port (X2)

The pin assignment of the COM connection differs according to the type of communication. The distinction is made between the following types of communication:

- RS232
- CANopen

Tab. 25: Pin assignment of the COM port (X2) for RS232

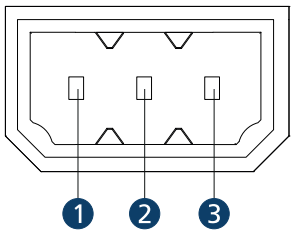
	Pin	Designation	Meaning
	1	TxD	RS232 interface transmit direction
	2	RxD	RS232 interface receive direction
	3	GND	Ground connection

Tab. 26: Pin assignment CAN1/CAN2 (X2) for CANopen

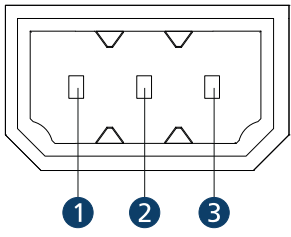
	Pin	Designation	Meaning
	1	CAN-H	CAN-High interface
	2	CAN-L	CAN-Low interface
	3	GND	Ground connection

Installation

4.2.4.3 Pin assignment of the motherboard (supply side)

I/O connection (X3)

Tab. 27: Pin assignment of the I/O connection (X3)

Pin	Designation	Meaning
1	U _{DD}	Power supply for external consumer loads
2	GND	Ground connection
3	DigOut 1	Digital output (open collector)
4	DigOut 2	Digital output (open collector)
5	DigOut 3	Digital output (open collector)
6	DigIn 1	Digital input
7	DigIn 2	Digital input
8	DigIn 3	Digital input
9	DigIn 4	Digital input
10	DigIn 5	Digital input
11	DigIn 6	Digital input
12	DigIn 7	Digital input
13	DigIn 8	Digital input
14	AnIn 1	Analog input
15	AnIn 2	Analog input
16	AGND	Ground connection for analog inputs

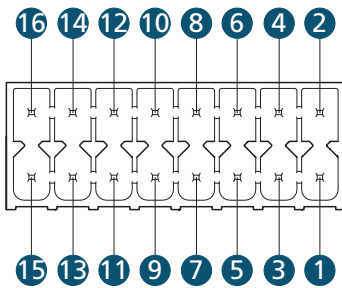

Tab. 28: Electrical data for the I/O connection (X3)

Designation	Value
Power supply for external consumers	5 V <100 mA
DigOut	low = GND high = high resistance 47 kΩ Max. 0.7 A
DigIn	<50 V 47 kΩ <1 MHz TTL level: low < 0.5 V, high > 3.5 V PLC level: low < 7 V, high > 11.5 V
AnIn	±10 V AGND

Installation

Voltage supply of the controller (X4)

Tab. 29: Pin assignment for the power supply of the controller (X4)

Pin	Designation	Meaning
1	GND	Ground connection
2	U_p	Power supply for controllers

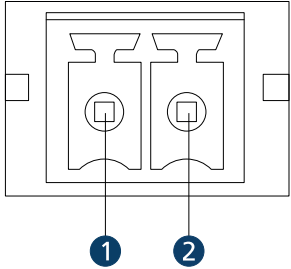

Tab. 30: Electrical data for the voltage supply (X4)

Designation	Value
Power supply for controller	12–50 V ≤100 mA (without external consumer)

Power supply of the motor (X5)

Tab. 31: Pin assignment for the power supply of the motor (X5)

Pin	Designation	Meaning
1	GND	Ground connection
2	U_{mot}	Power supply of the motor

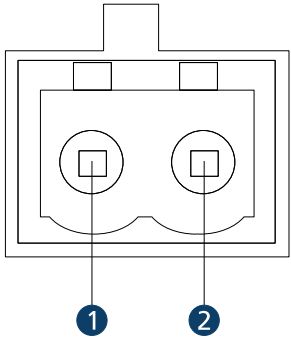

Tab. 32: Electrical data for the voltage supply (X5)

Designation	Value
Motor power supply	≤50 V

Installation

EtherCAT port (IN/OUT)

Tab. 33: Pin assignment EtherCAT (IN/OUT), connector: RJ45

Designation	Meaning
IN/OUT	EtherCAT communication Pin 1: TxD+ Transmission Data + Pin 2: TxD- Transmission Data - Pin 3: RxD+ Receiver Data + Pin 6: RxD- Receiver Data -

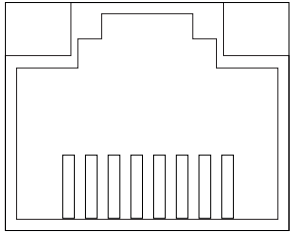

Tab. 34: Pin assignment EtherCAT (IN/OUT), connector: DIN

Designation	Meaning
IN/OUT	EtherCAT communication Pin 1: TxD+ Transmission Data + Pin 2: TxD- Transmission Data - Pin 3: vGND Virtual Ground Pin 4: vGND Virtual Ground Pin 5: RxD+ Receiver Data + Pin 6: RxD- Receiver Data -

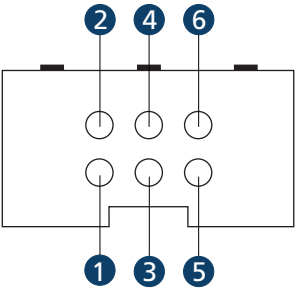

4.2.5 Motherboard: connection at the motor side

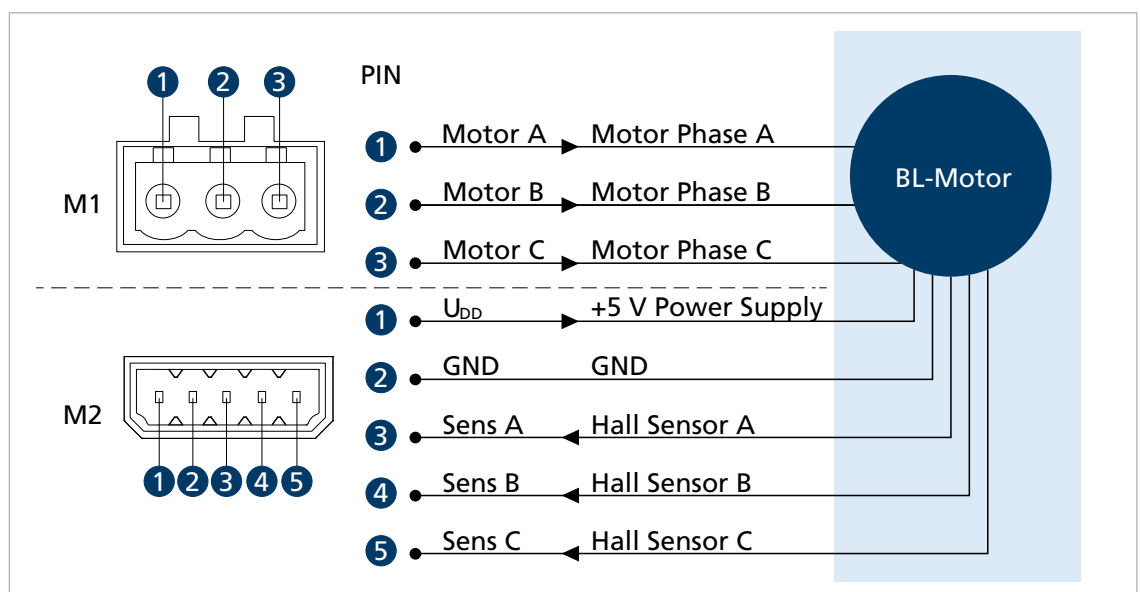

Fig. 14: BL/LM motor with Hall sensors

Installation

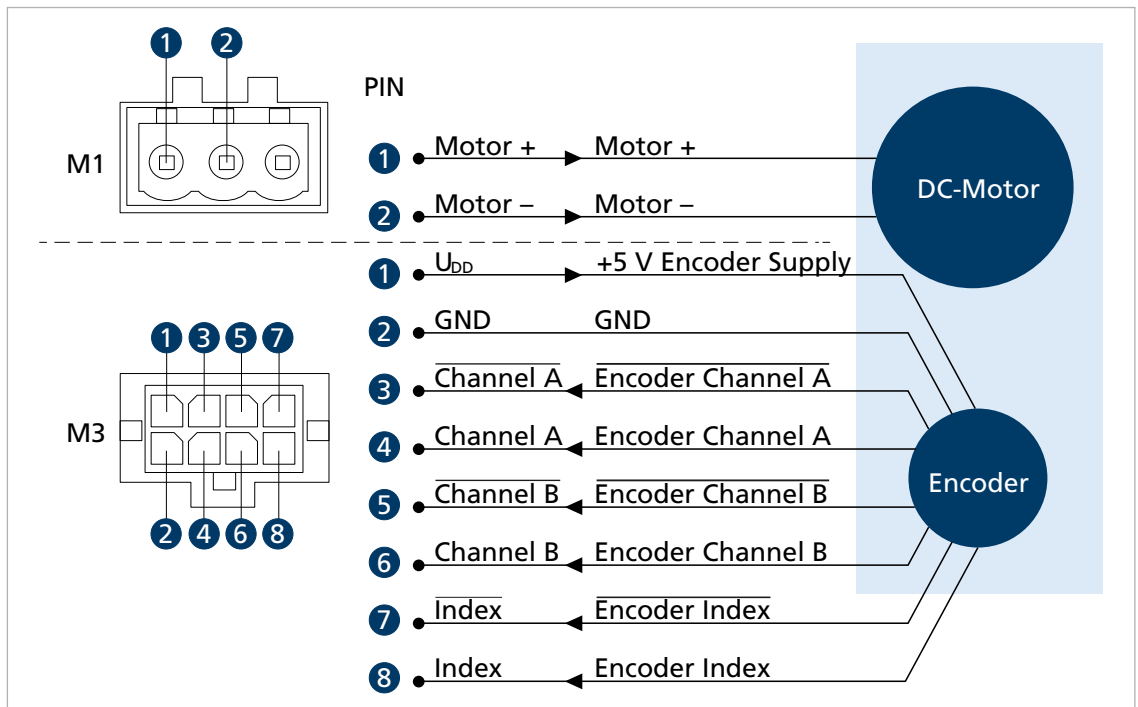

Fig. 15: DC-motor with incremental encoders

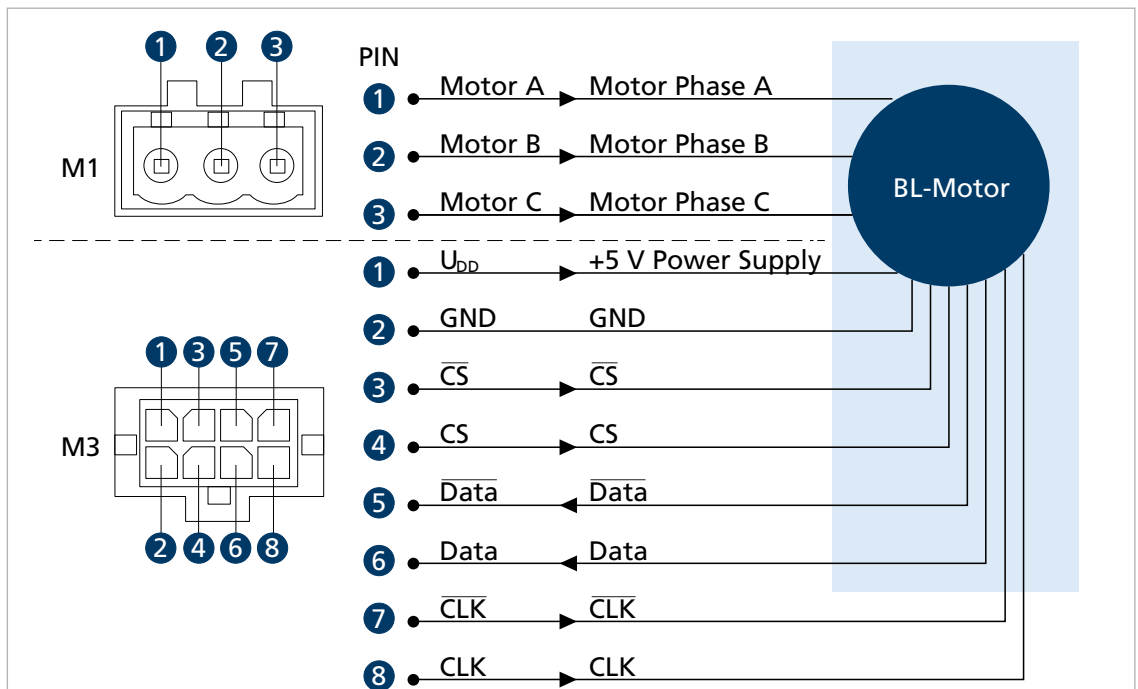

Fig. 16: BL motor with absolute encoders

Installation

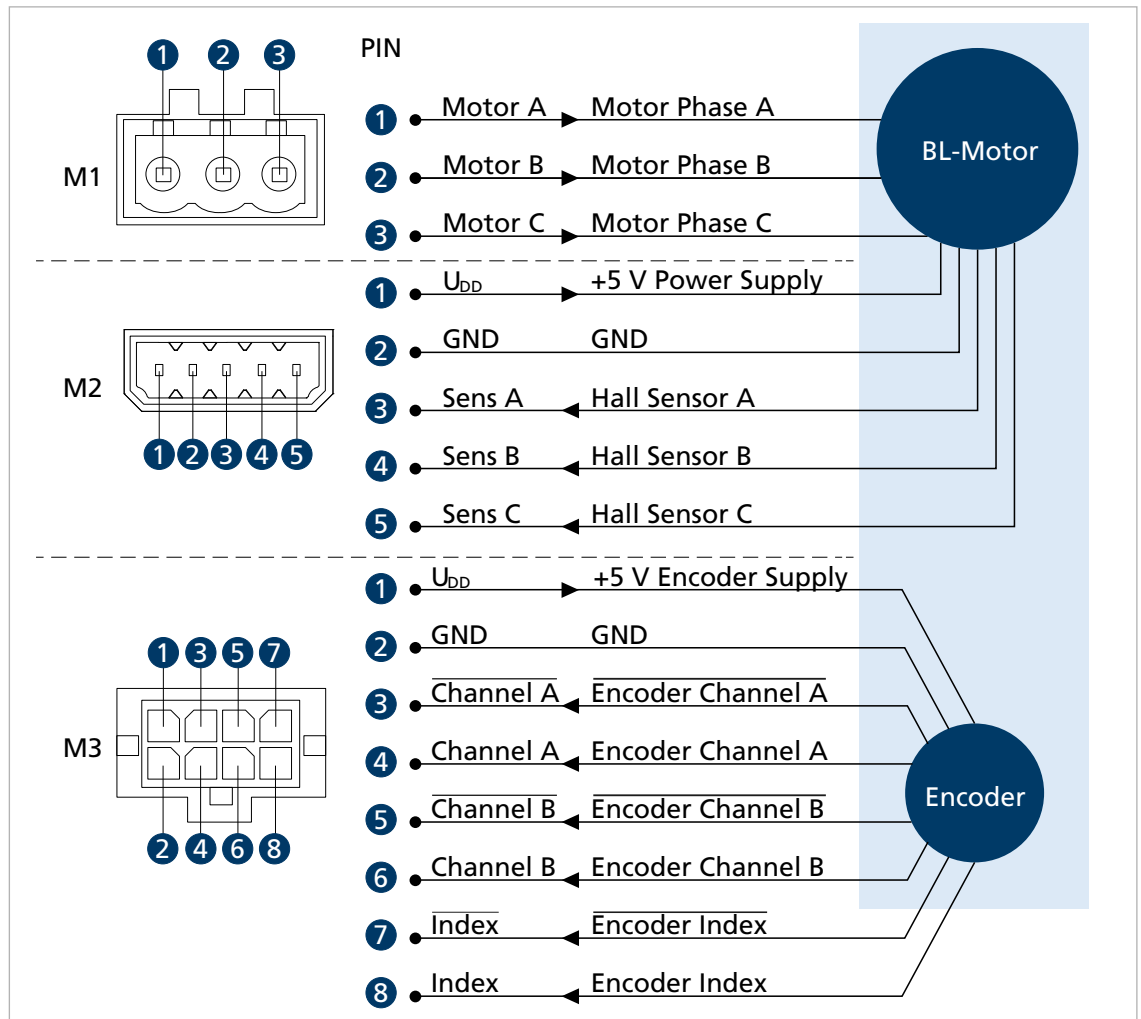

Fig. 17: BL motor with Hall sensors and incremental encoders

Installation

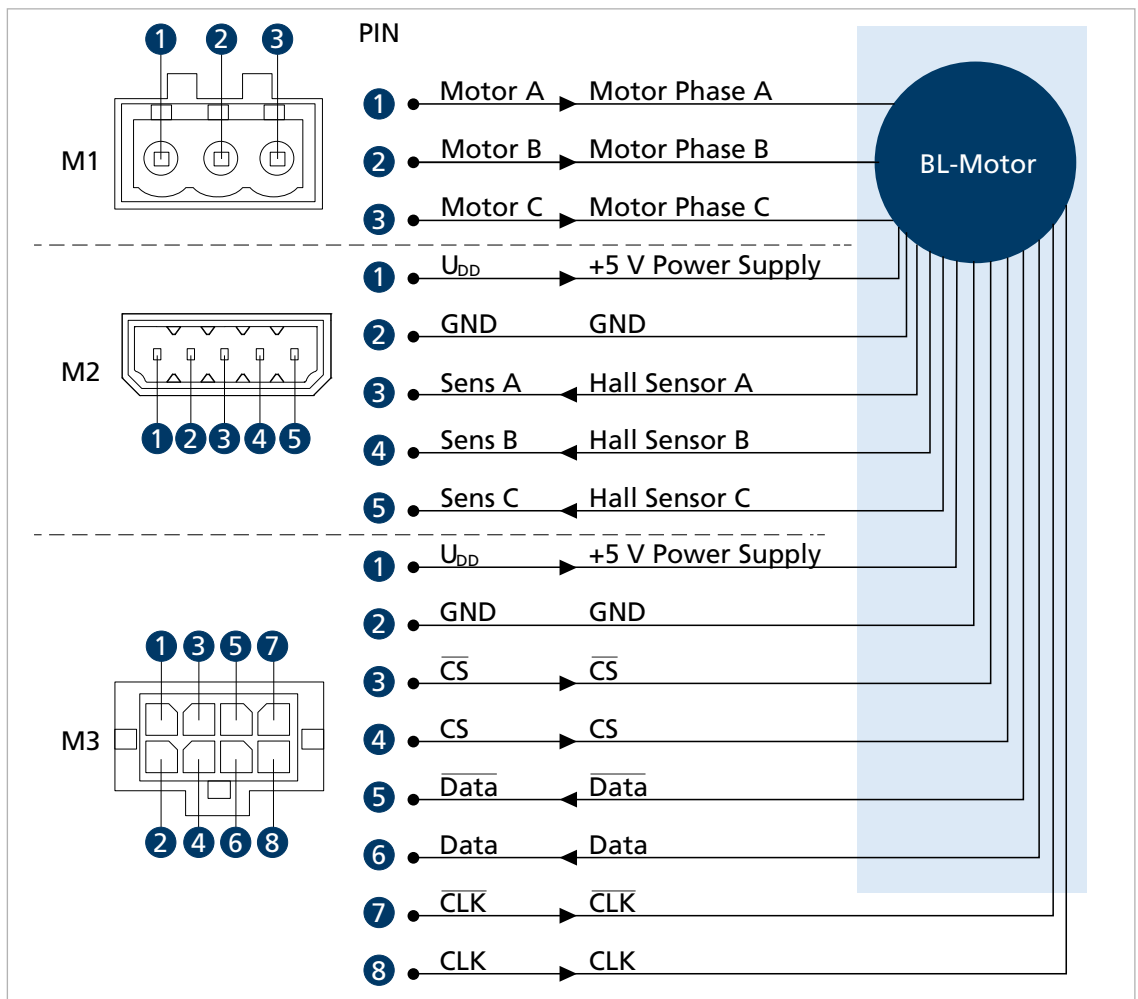

Fig. 18: BL motor with Hall sensors and absolute encoders

Installation

4.2.6 I/O circuit diagrams

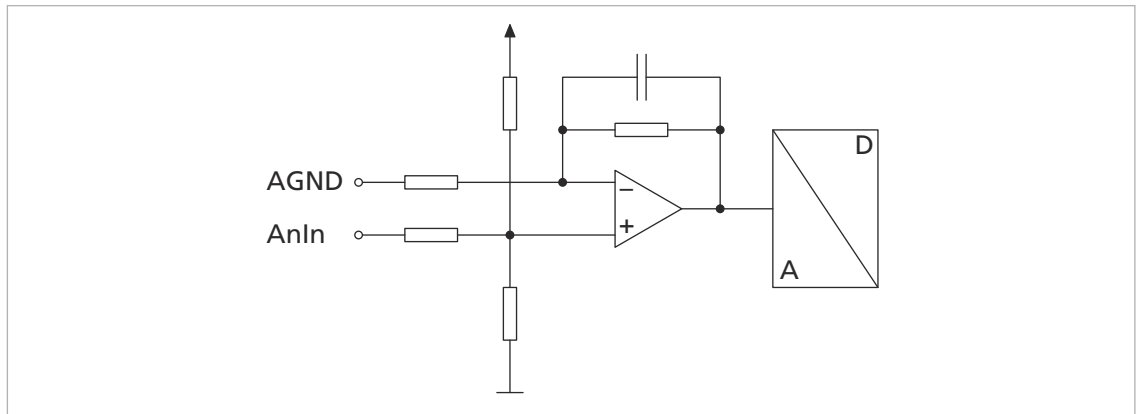

Fig. 19: Analog input circuit diagram (internal)

i So that the voltage drop on the supply side does not affect the speed specification value, connect the analog input ground (AGND) to the power supply ground (GND).

The analog inputs are executed as differential inputs. Both inputs use the same reference input.

The analog inputs can be used flexibly:

- Specification of set-points for current, speed or position
- Connection of actual value encoders for speed or position
- Use as a free measurement input (queried via the interface)

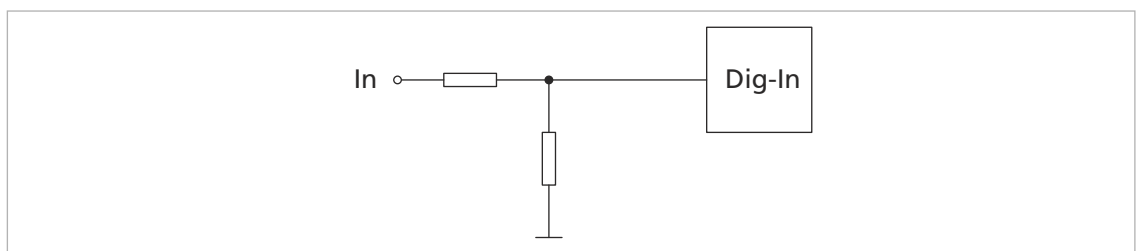

Fig. 20: Digital input circuit diagram (internal)

The digital inputs are switchable from the input level (PLC/TTL). The digital inputs can be configured for the following purposes (see the Drive Functions):

- Digital input for reference and limit switches
- Connection of an external encoder
- PWM (Pulse Width Modulation) set-point specification for current, speed and position

Installation

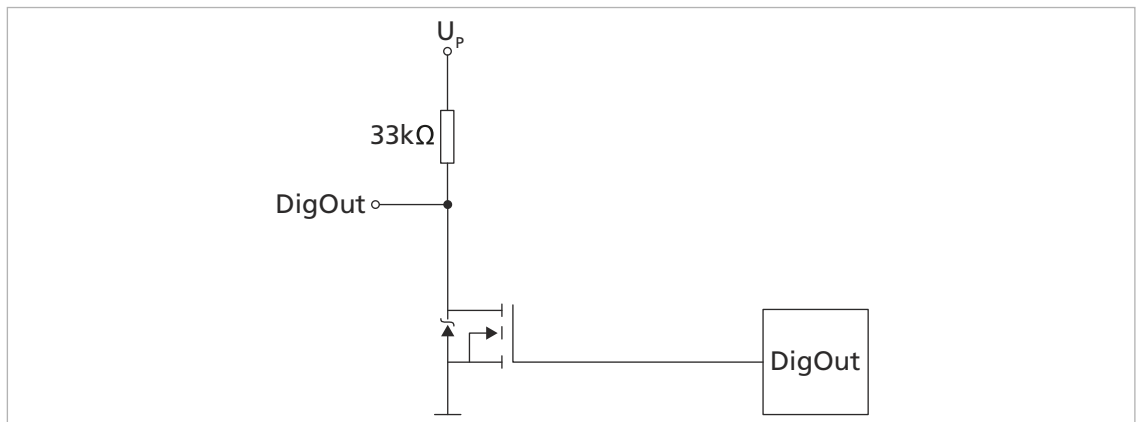

Fig. 21: Digital output circuit diagram (internal)

The digital output has the following properties:

- Open collector switch to ground
- Monitored output current (switch opens in the event of an error)

A digital output can be assigned to an error output. It can be freely programmed.

4.2.7 External circuit diagrams

Bipolar analog set-point specification via potentiometer

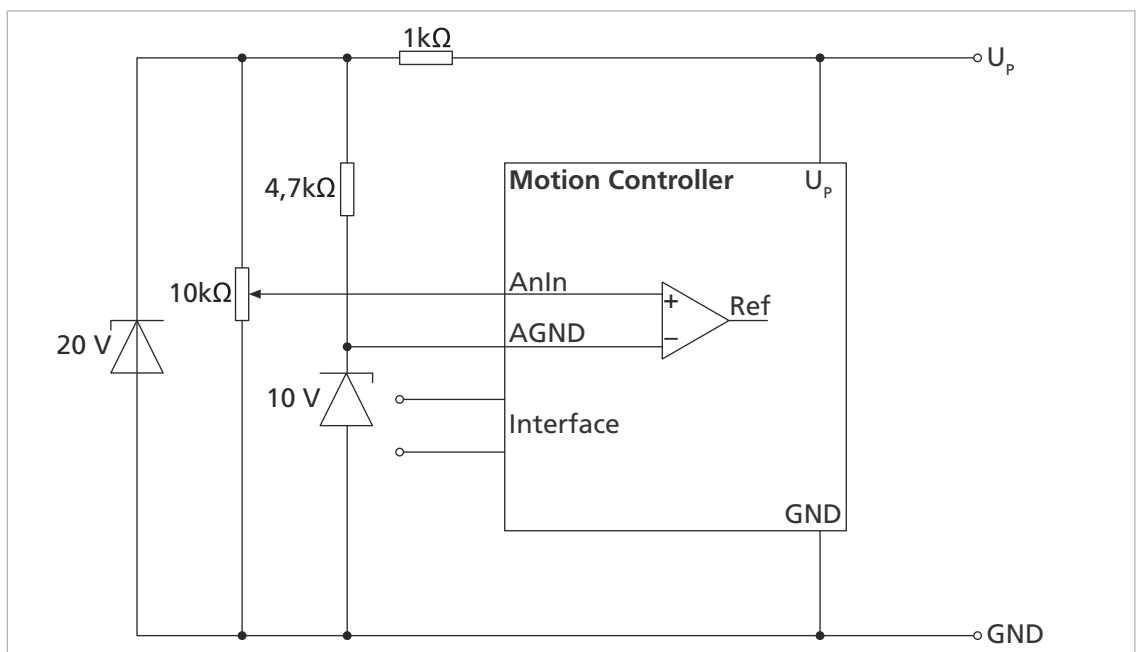

Fig. 22: Bipolar analog set-point specification via potentiometer

Installation

Analog set-point specification via potentiometer with internally set offset and scaling

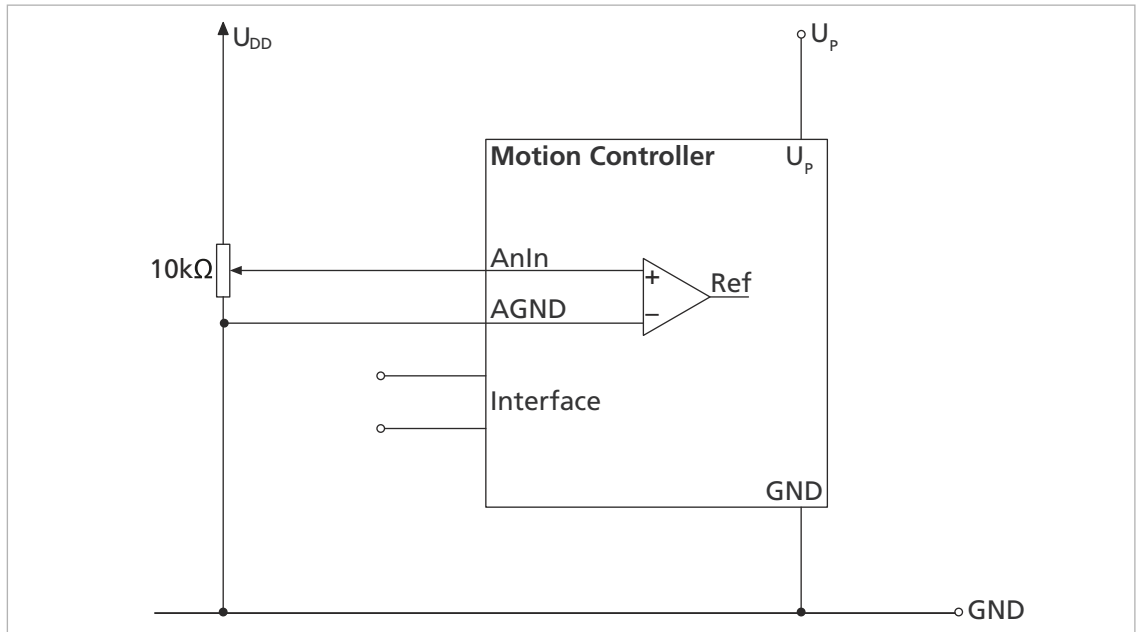

Fig. 23: Analog set-point specification via potentiometer with internally set offset and scaling

Connection of reference and limit switches

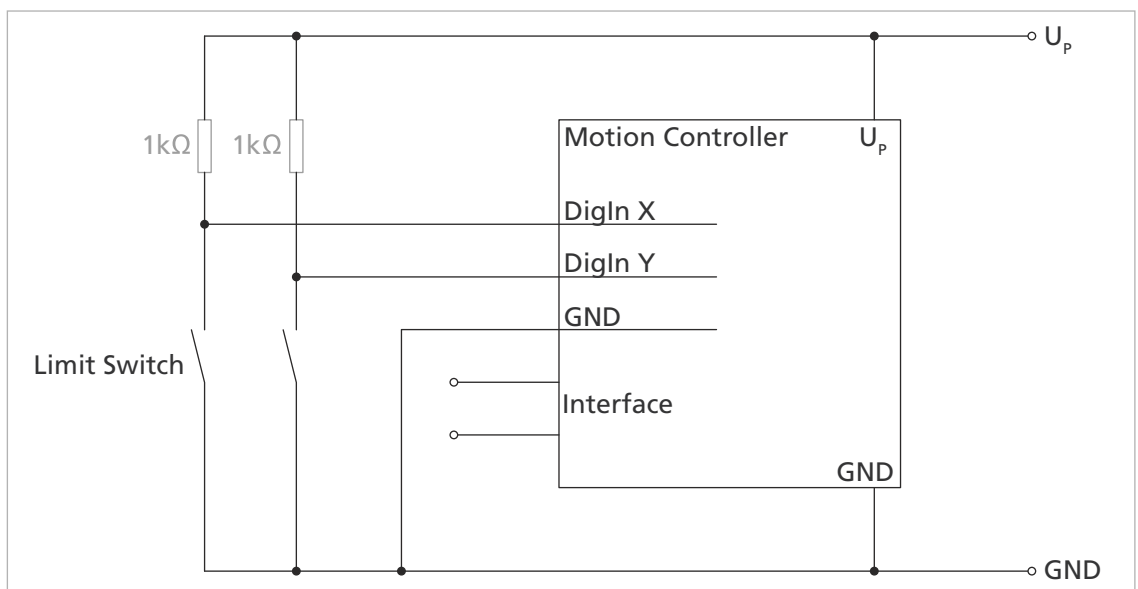

Fig. 24: Connection of reference and limit switches

i Depending on the type of switch it may be necessary to use additional pull-up resistors. No internal pull-up resistors are incorporated in the Motion Controller.

Installation

Connection of an external incremental encoder

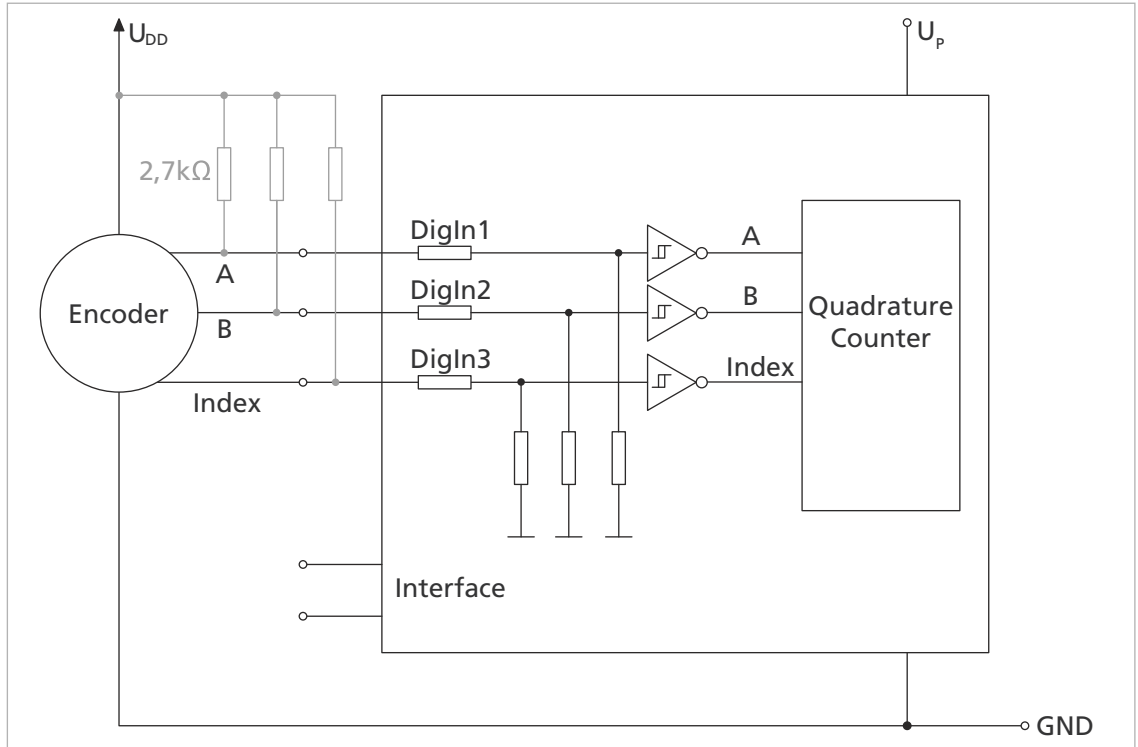

Fig. 25: Connection of an external incremental encoder

i Depending on the type of encoder it may be necessary to use additional pull-up resistors. No internal pull-up resistors are incorporated in the Motion Controller.

Wiring between PC/controller and a drive

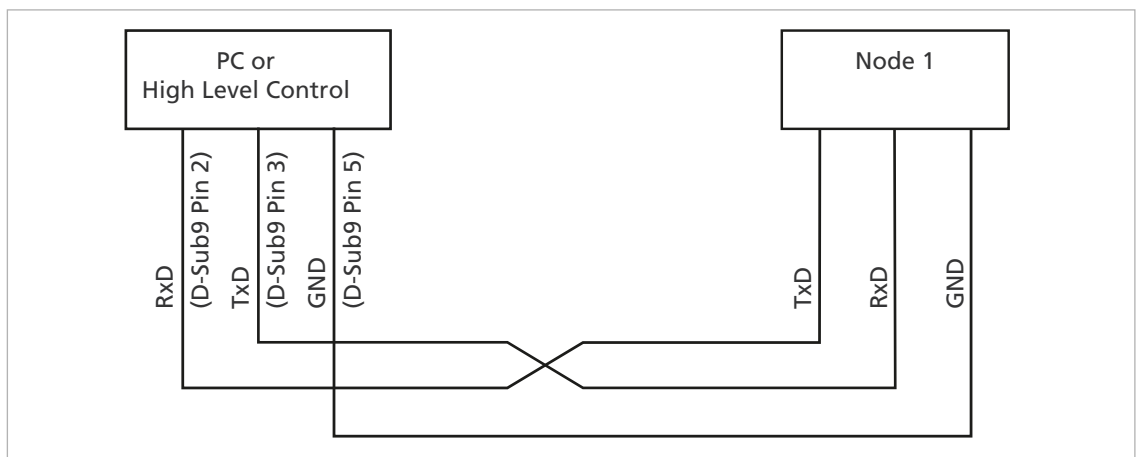

Fig. 26: Wiring between PC/controller and a drive

Installation

Wiring with several Motion Control Systems in RS232 network operation

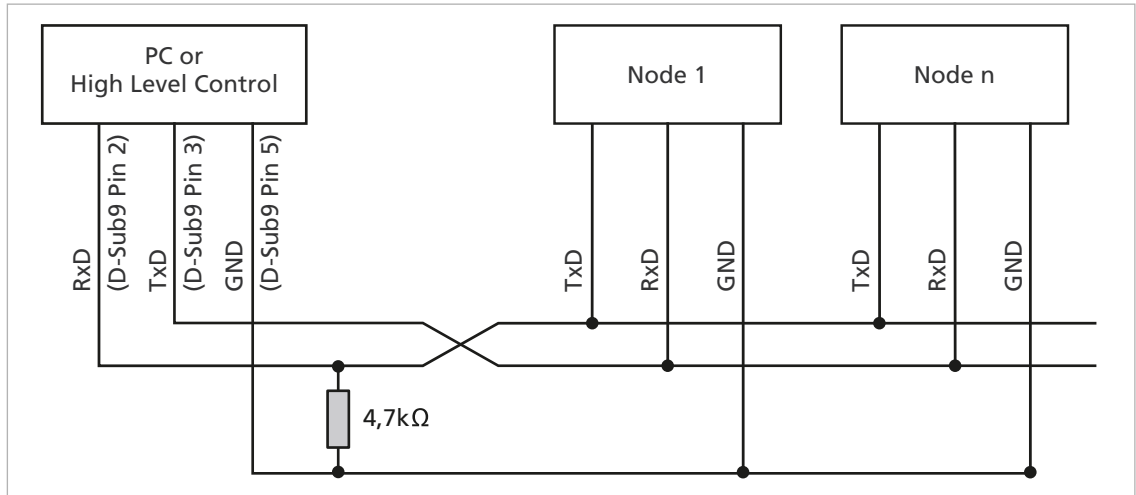

Fig. 27: Wiring with several Motion Control Systems in RS232 network operation

i Depending on the number of networked Motion Control Systems, a smaller value may be necessary for the pull-down resistor.

Connection to the CANopen network

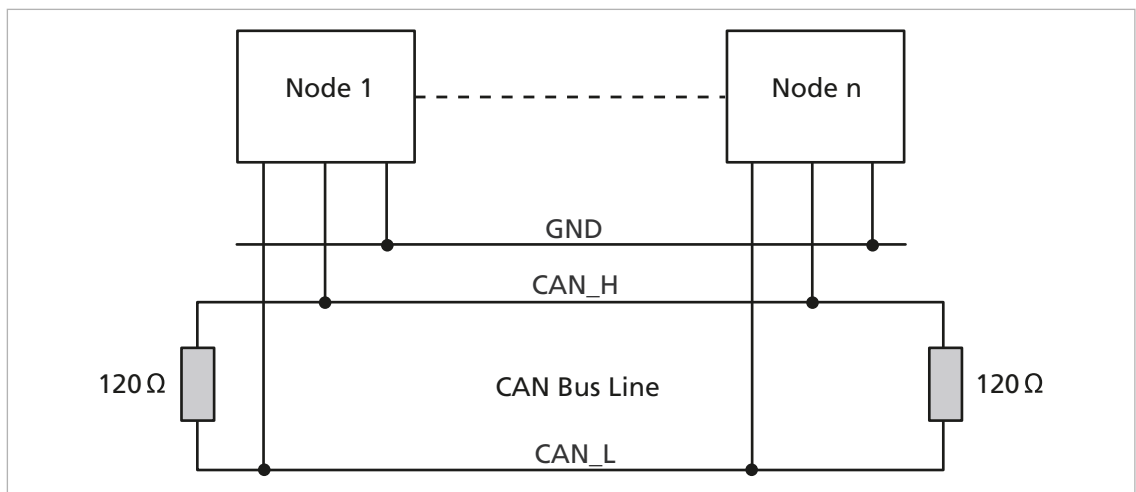

Fig. 28: Connection to the CANopen network

i If the CAN wiring is not laid in a straight line it may be necessary to individually optimize the amount and location of the terminating resistors. For instance in a star network a central 60 Ohm terminating resistor may be more suitable. When the optimum arrangement of terminating resistors is fitted, no accumulation of error frames should be evident.

Installation

4.3 Electromagnetic compatibility (EMC)

- ▶ Follow the instructions in the following chapters to perform an EMC-compliant installation.

WARNING!

The Motion Controller can cause high-frequency interference which can affect the function of electronic implants and other electronic devices.

- ▶ Take appropriate interference suppression measures, particularly during use in residential environments.
- ▶ Observe the notices for EMC-compliant setup.

NOTICE!

Drive electronics with qualified limit values in accordance with EN-61800-3: Category C2 can cause radio interference in residential areas.

- ▶ For these drive electronics, take additional measures to limit the spread of radio interference.

4.3.1 Considered systems

The following considerations assume installations that can be described with the following circuit diagrams.

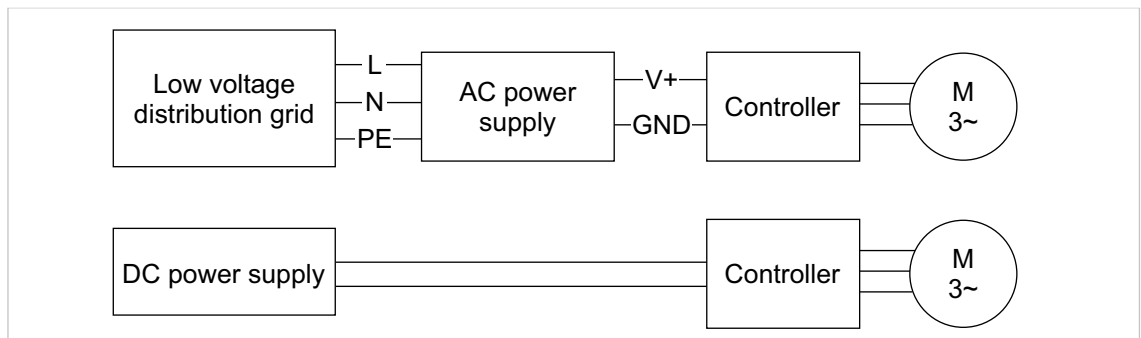

Fig. 29: Circuit diagrams of the considered systems

Installation

AC-mains system

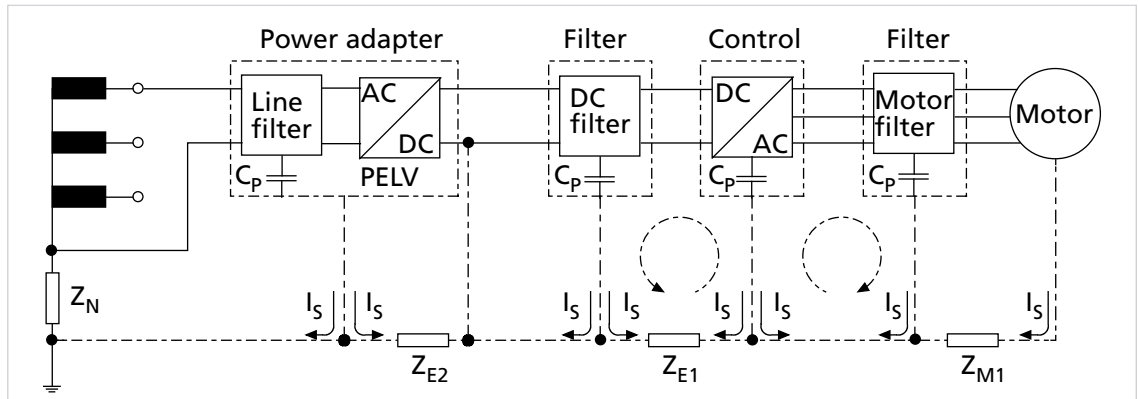

Fig. 30: Interference sources in an AC-mains system

- Z_N Mains impedance of mains transformer – power supply connection
- Z_{E1} Common-mode impedance of electronics on DC side
- Z_{E2} Common-mode impedance of electronics on AC side – power supply connection
- Z_{M1} Impedance of motor housing – controller
- I_s Parasitic current
- C_p Parasitic capacitance/filter capacitance

Parasitic current usually arises from the following components:

- Semiconductors
- Capacitive portion of the motor supply line
- Parasitic elements in the motor

Operating the motors with PWM is the cause here.

The DC-DC converter in the device and the used switching power supply also produce interference that could affect the mains. The created interference of the DC-DC converter in the device is, however, normally of little relevance due to the switched power (<5 W).

In contrast to this are the switching power supply, which supplies the controller with motor voltage or electronics voltage, and the PWM drive. Depending on the design, quality and effectiveness of the integrated filters (where present), the power supply can also cause interference.

i The qualitative assessment of a power supply can be performed with an interference voltage test and a resistive load (e.g., fanless heater / hot plate).

DC-mains system

Prerequisite for connecting to the DC mains is that the switching interference of the power supply be negligible. A linear power supply can be used to reduce this interference.

Installation

Problem solutions

The interference may vary depending on load and installation.

Solution	Mode of action	Benefits	Disadvantages
3-phase common-mode choke / ferrite ring around all motor phases	Removes common-mode interference of the motor	<ul style="list-style-type: none"> Removes RF common-mode interference Fast testing possible 	<ul style="list-style-type: none"> Does not remove all interference Fabrication necessary
PWM motor filter (e.g., EFM 5003 6501.00357)	Removes switching noise on the motor cable through DC averaging	Interference limited to input side	Does not remove all RF interference
Motor filters and ferrites (e.g., EFC 5008 6501.00351)	Removes RF interference on the motor cable	Optimum for radio emissions	Does not remove all low-frequency interference
Input filter upstream of the controller (e.g., EFS 5004 6501.00350)	Removes interference of the switching regulator and part of the motor interference on DC networks	Pass an interference voltage measurement with correct wiring	Does not remove interference on the motor side
Mains filter upstream of the switching power supply	Removes common-mode interference of the power supply	Very cost-effective solution	<ul style="list-style-type: none"> Often only effective for power supply Does not remove all interference

The mentioned variants are effective only if the following chapters are followed correctly.

4.3.2 Functional earthing

DANGER!

Danger to life through ground leakage currents ≥ 3.5 mA

- ▶ Check the grounding of the devices for proper installation.

The grounding system is essential for discharging parasitic current and for a potential distribution in the system that is as uniform as possible. The most efficient systems have a star or mesh shape. A star-shaped connection is easier to implement.

- ▶ Ensure an adequate cross section and a very good electrical ground connection so that the contact resistances are low not only for the low-frequency currents.

The ground connection can be improved, e.g., by removing the oxide layers from the ends of conductors with fine sandpaper.

For electrical safety:

- ▶ Ground in accordance with current standards and guidelines.
- ▶ Use separate protective conductors (PE) for all necessary parts (e.g., mains supply, motor, controller).
- ▶ Keep grounding cable as short as possible.

For functional earthing:

- ▶ Use a braided shield that is meshed as tightly as possible.
- ▶ Direct contact with the grounding plate is to be preferred.
Therefore, avoid contact with the controller and then with the grounding plate.
- ▶ Connections made over a large surface area are to be preferred.

Installation

4.3.3 Cable routing

⚠ WARNING!

Voltages >25VAC are generated and transmitted in the drive system.

- ▶ Set up the wiring of the drive system in a touch-proof manner.
- ▶ Only operate the drive system on an SELV or PELV power supply network.

The cable routing depends on various factors, such as:

- Is the cable shielded, twisted?
- Were interference-reducing measures taken?
- What material and what cable routing are used in the cable duct?
- Over what surface is the cable routed?

Observe the following when laying the cables:

- ▶ Use a full-surface, u-shaped and, if possible, metal cable duct.
- ▶ Lay the cables near the corners of the cable duct.
- ▶ Separate the cables by function where possible.
- ▶ Maintain distances when laying the cables.

The distances may vary depending on the zone in the switching cabinet.

- ▶ If possible, all cables should be twisted pairs or twisted and shielded in function groups (e.g., motor phases together, Hall sensors and supply together).

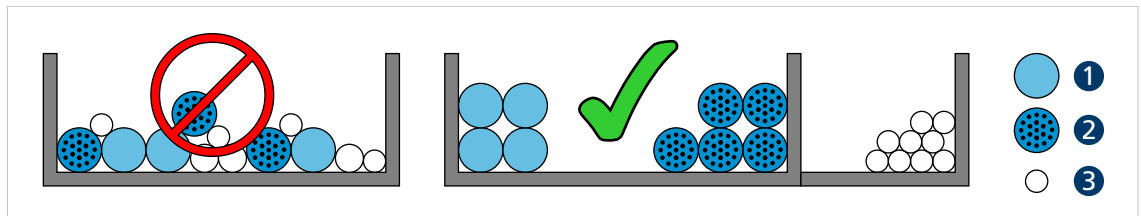

Fig. 31: Laying in the cable duct

- 1 High-current cable
- 2 Digital cable

- 3 Sensor cable

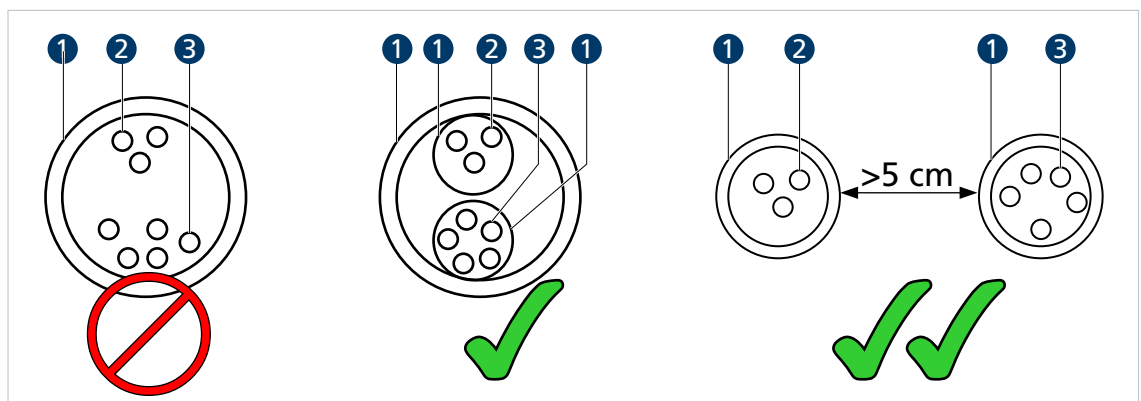

Fig. 32: Grouping and shielding of the cables

- 1 Shielding
- 2 Motor phase

- 3 Hall sensor

Installation

4.3.4 Shielding

- ▶ Shield cables in all cases.

Shield cables that are longer than 3 m with tightly meshed copper braiding.

- ▶ Shield all supply lines according to current guidelines/standards (e.g., IPC-A-620B) and connect using (round) shield clamp.

In special cases (e.g., with pigtail) or after qualification, the shield can be omitted for the following cables:

- Cables with length <50 cm
 - Cables with low power supplies (e.g., <20 V)
 - Sensor cables
- ▶ Connect shield clamps to a low-impedance (<0.3 Ω) grounding bar or grounding plate.
 - ▶ Establish a star-point earth connection (see chap. 4.3.2, p. 45).
 - ▶ Lay the motor phases in a shield, separate from the sensor or encoder signals, and connect on at least the motor side (see 1 or 2 in Fig. 33).

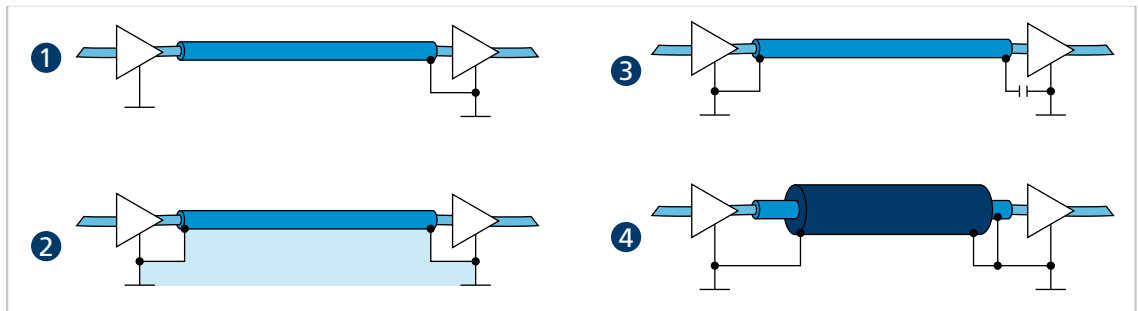

Fig. 33: Various possibilities for the shield connection

- 1 *Suppressing electrical fields*
- 2 *Alternating magnetic field*
- 3 *Interruption of the ground loop for direct currents or low-frequency currents*
- 4 *Discharging parasitic currents to the reference potential*

The sensor signals can optionally be laid with the motor phases in a shared cable/insulation hose using another outer braided shield. This outer braided shield must be connected at both ends (e.g., 4 in Fig. 33). A solution such as 2 in Fig. 33 is not functional in every case for this configuration. If this is not possible by means of a ground offset, establish the RF connection via specially suited capacitors (e.g., safety capacitors such as Y1/Y2/X1/X2, see 3 in Fig. 33). In this case, do not connect the shield multiple times except at the motor connection and controller side.

Installation

4.3.4.1 Establishing the shield connection

The best results when establishing a shield connection on the cable are achieved in the following way:

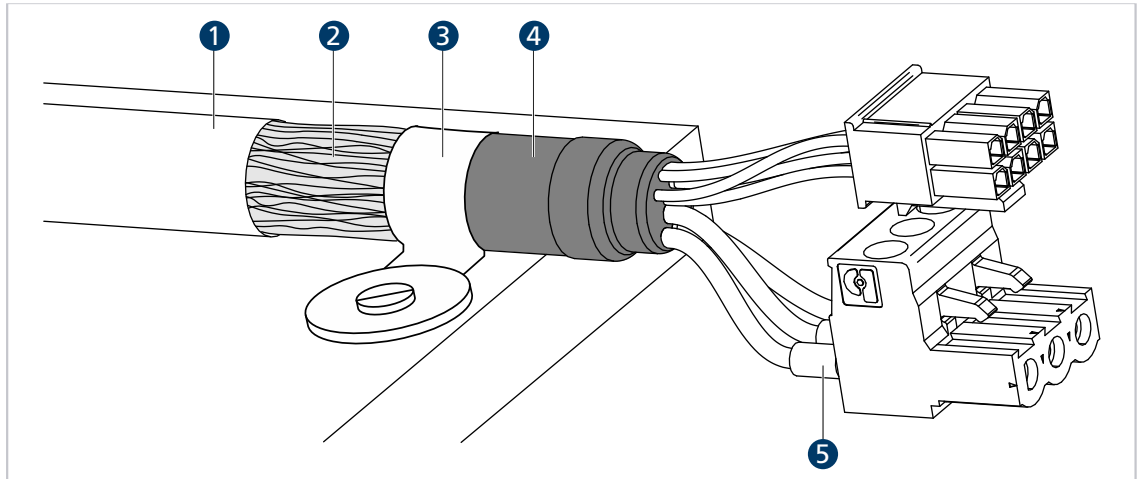

Fig. 34: Motor cable shield connection

- | | |
|----------------------|----------------------|
| 1 Outer cable shield | 4 Heat-shrink tubing |
| 2 Braided shield | 5 Crimp-sleeve |
| 3 Shield clamp | |

1. Remove approx. 50-100 mm from the outer cable shield (1). Make certain that none of the fibers of the braided shield (2) are destroyed.
2. Either push back the shield or roll it up and fasten with heat-shrink tubing (4).
3. Optionally fit crimp-sleeves on the cable ends (5) and attach to the plug connectors.
4. Fasten the shield and the fixed end of the heat-shrink tubing with a cable tie (3).

Installation

4.3.4.2 Establishing shield connection with cable lug

A shield connection with cable lug should be avoided whenever possible. If it is necessary, however, the connection should be established as follows.

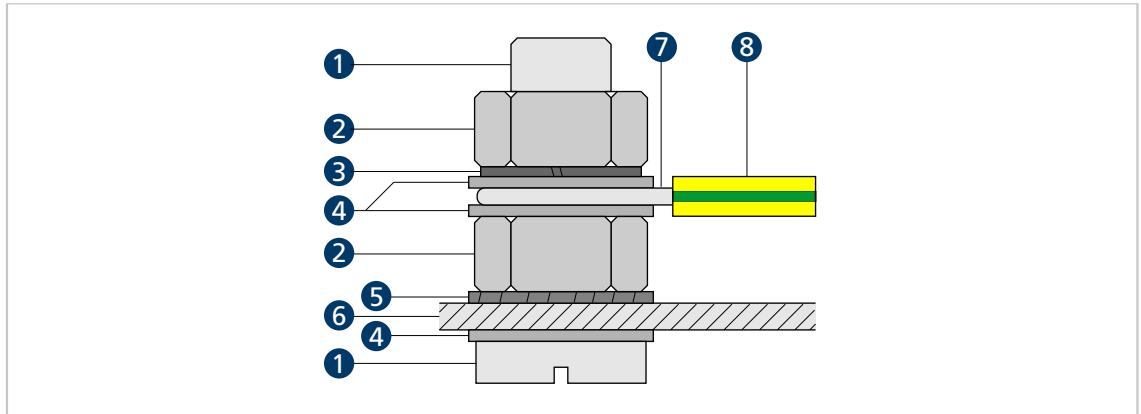

Fig. 35: Shield connection with cable lug

1	Screw	5	Lock washer
2	Nut	6	Wall
3	Spring washer	7	Wire eyelet
4	Washer	8	Protective conductor

1. Scrape the surface around the hole to remove as much of the oxide layer as possible.
2. Guide screw with washers through the cable lug.
3. Place lock washer on the screw.

Depending on the screw length, also position the lock washer against the roughened surface.

4. Fix screw with nut on the bottom side or screw into the thread.

Installation

4.3.5 Sensor and encoder interfaces

Various solutions for different cable lengths are described in chap. 4.2.2, p. 24. The objective here should be to increase the signal quality to a reliably usable minimum.

The sensor systems used at FAULHABER for angle determination should be divided according to their useful frequency range. Depending on the frequency range, various filter measures are suitable.

- Analog Hall sensors (very low frequency)
- Digital Hall sensors and quadrature interfaces
- Absolute encoder

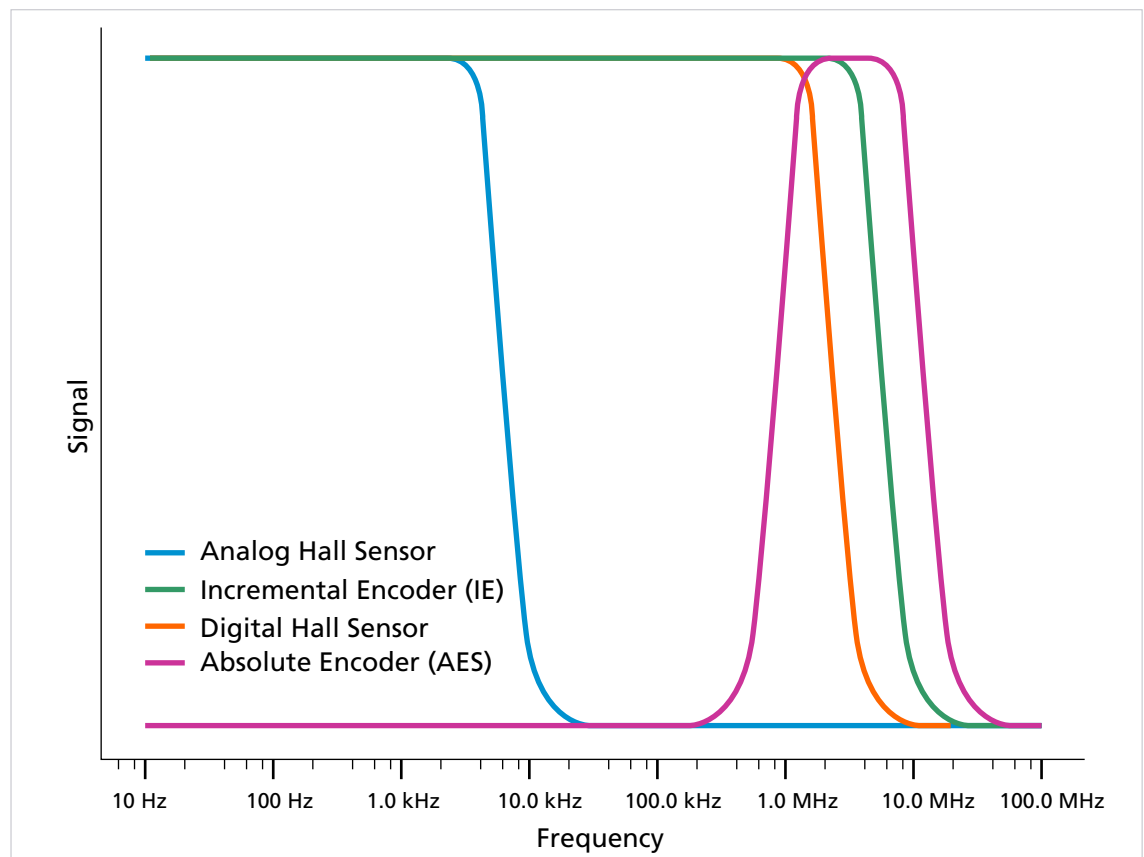

Fig. 36: Useful frequency ranges of the encoders

- ▶ To evaluate the interference on the signal (transmission quality), measure the signals.
- ▶ Make certain that no parasitic effects are measured. Select the reference potential correctly and measure directly on the controller if possible.

The following statement applies to all mentioned sensor systems: Differential signal transmission with line driver is an effective measure for increasing the interference immunity for longer cable lengths.

Additional measures for the various sensor systems can be found in the following sections.

Installation

4.3.5.1 Analog sensors and analog Hall sensors

- ▶ Where possible, shield analog sensor cables and lay them apart from (shielded) motor cables.
- ▶ Connect the shield on one end, ideally on the motor side.

 The signal quality can be improved with a capacitor (470 nF, dielectric strength > 100 V) between device shield and sensor supply (+5 V).

4.3.5.2 Incremental encoders / Digital Hall sensors / Digital sensors

 Due to the increased signal hysteresis, digital Hall sensors are more robust than analog Hall sensors.

 Incremental encoders are robust due to a four-edge evaluation in the controller.

4.3.5.3 Encoders with absolute interface

- ▶ Connect the shield of the encoder lines on both ends.

On the controller side near the encoder plug connector, a terminal resistance of 120 Ω is highly recommended between Data+ and Data-. This is already integrated in one of the special numbers (SN 6419) of the controller.

Alternatively, a so-called split termination can be used instead of the 120 Ω to increase the interference resistance. See also technical manual AEMTL (manual no. 7000.0x070).

 In the case of an absolute encoder interface, signal interference immediately results in invalid position values during the interference. A more interference-immune, differential data transmission is therefore advantageous.

Installation

4.3.6 Using filters

The filters are divided into various function and current ranges.

Filter types:

- Input-side filters: filters on the power supply side
- Motor-side filters: filters that are connected between controller and motor in the motor phases

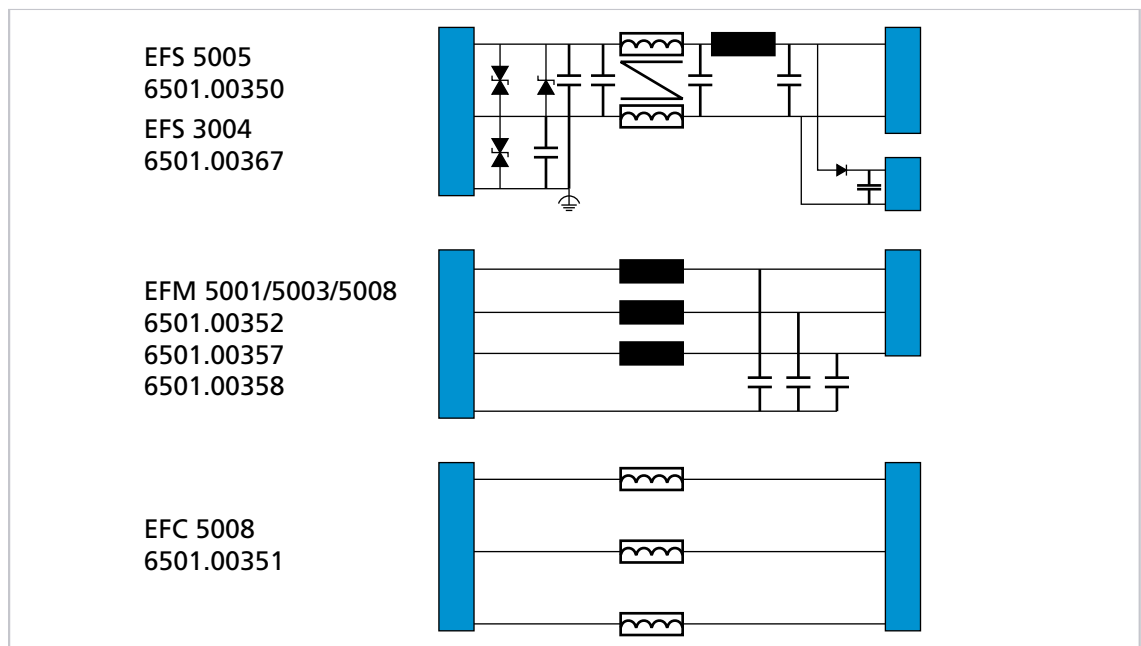

Fig. 37: Filter categories from FAULHABER

Installation

4.3.6.1 Installing the Motion Controller PCB in the top-hat-rail housing

The test setup in Fig. 38 shows an example for a Motion Controller PCB installed in a top-hat-rail housing.

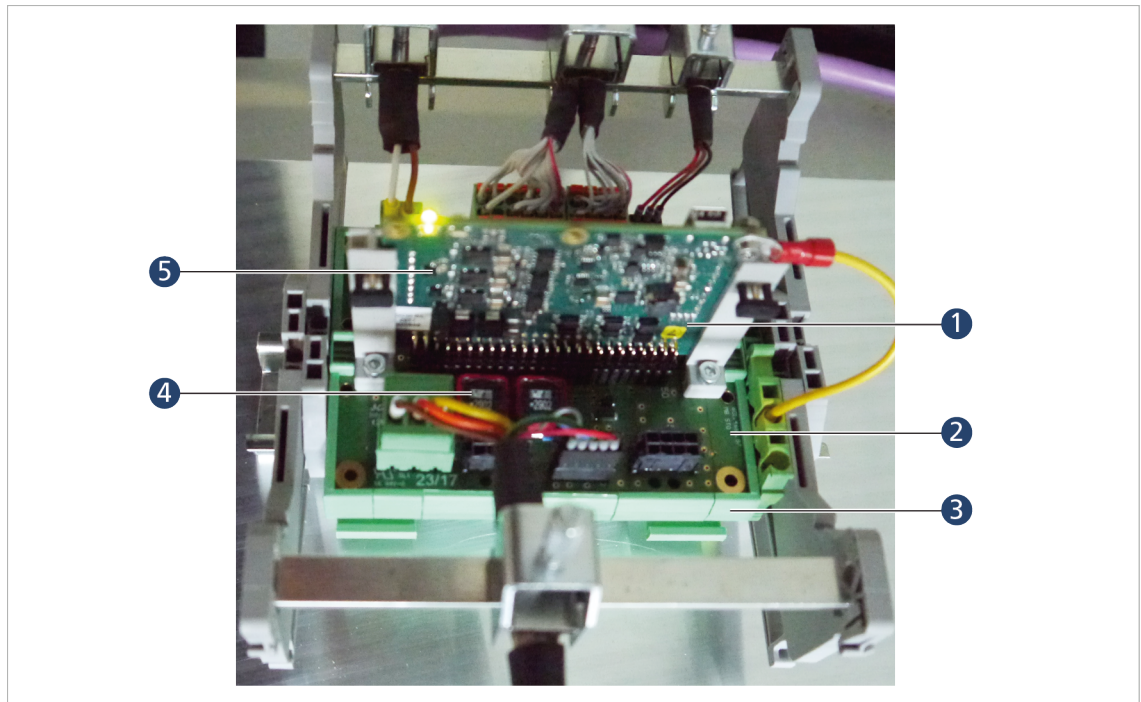

Fig. 38: Example for installation in a top-hat-rail housing

- | | | | |
|---|------------------------------|---|------------------------------------|
| 1 | <i>Motion Controller PCB</i> | 4 | <i>Motor-side filter</i> |
| 2 | <i>Motherboard</i> | 5 | <i>Input-side filter (covered)</i> |
| 3 | <i>Top-hat-rail housing</i> | | |

The following components from Phoenix Contact could, for example, be used as a suitable top-hat-rail housing:

Quantity	Component designation	Manufacturer number
1	UMK BE 45	2970015
1	UMK BE 22.5	2970028
1	UMK BE 11.25	2971535
2	UMK SE 11.25	2970002
2	UMK FE	2970031

Installation

4.3.6.2 PWM filter (motor-side)

The PWM filters are designed for the maximum motor supply voltage with a nominal value of 50 V (+10%) and allow a nominal motor current of 1, 3 or 8 ampere. With DC-motors, the supply line RMS value can be used. A peak current of 3 s can be assumed.

 The motor filters are only suitable for the PWM frequency of 100 kHz. Lower PWM frequencies must be explicitly tested, as the power losses increase at lower PWM frequency.

For the proper filter effect, all PWM filters require a 0 V connection, which should be connected as short as possible to the 0 V voltage (GND) of the motor supply (connection X5 of the supply side).

4.3.6.3 Emission-reducing, ferrite-based filters (motor side)

These filters only require three phase connections. The 0 V return line (see chap. 4.3.6.2, p. 54) is not required. All PWM frequencies can be used. The filters reduce the rise time of the motor voltage/current and thereby reduce the high-frequency coupling currents on the shield.

4.3.6.4 Input-side filters

These filters are for applications that either cannot use the motor filter (e.g., integrated controllers) or in which the filtering by the motor filters is not sufficient. In this case, two filtering measures are used:

- Measure comparable to large capacitors (approx. >100 μF) as close as possible to the controller and, where possible, low-ESR capacitances
- Discharge of common-mode interference with a common-mode choke, a low-pass filter and capacitors between functional earth and DC power supply

4.3.6.5 Insulation resistance

The filters from FAULHABER are not intended for an insulation resistance test. Discharging of the common-mode interference with capacitors prevents a meaningful result from an insulation resistance test.

Installation

4.3.6.6 Coiling ferrite ring

Ideally, ferrites made of manganese-zinc material are used that are active in the 1...10 MHz range. Typical diameters are between 25 and 35 mm onto which two to three windings with all 3 motor phases are wound simultaneously.

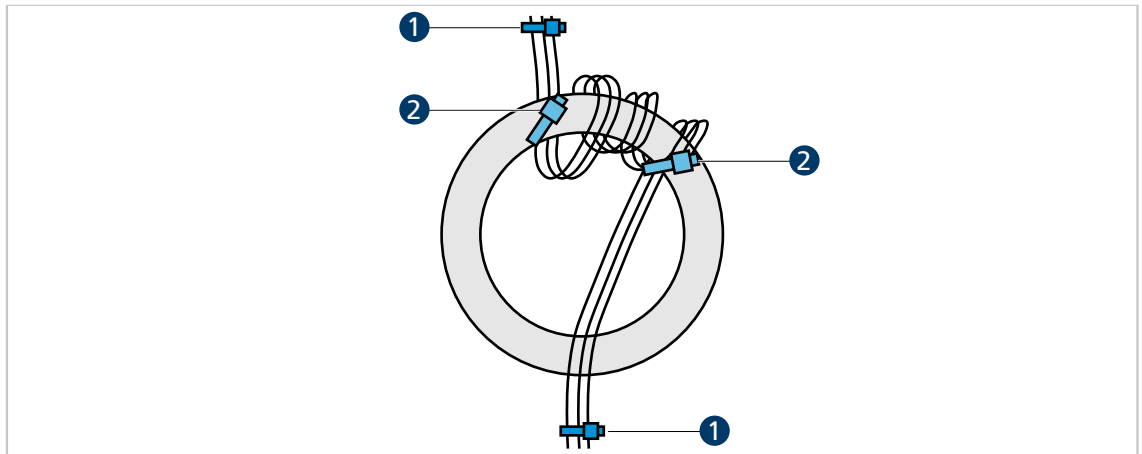

Fig. 39: Coiling ferrite ring

1 Fastening the motor phase cables

2 Fastening on the ferrite ring (optional)

1. Fasten motor phase cables, e.g., with cable ties (1), so that the motor side end of the cable points away from the user and the plug end of the cable points toward the user.
2. Simultaneously guide all three phases through the ferrite ring from below.
3. Guide the wound stranded wires back through the ring clockwise next to the first stranded wires so that a winding is created.
4. Wrap 2 further windings directly next to the existing windings in the same way.
 - ↪ There are 9 stranded wires in the ferrite ring.
5. Again secure the motor phase cables, e.g., with cable ties (2), on the ferrite ring.

4.3.7 Error avoidance and troubleshooting

1. Can the problem clearly be traced back to the FAULHABER drive system?
 - a) Switch the output stage off and on.
The voltage controller mode is suitable here.
 - b) Unplug controller supply voltages or operate controller via a separate external power supply used solely for this purpose.
 - c) If present, switch off unnecessary system components.
2. Have the measures shown in chap. 4.3.2, p. 45 been performed and tested?
 - a) Can a uniform ground potential be ensured, e.g., by using large cable cross sections?
 - b) Is the RF quality of the connections ensured?
 - Establish connection through metal-to-metal connection elements.
 - Remove paints or other insulating materials. Check that the shield connection is correct.
3. Were the recommended cables used?
 - a) Select motor cables in the accessory catalog.
 - b) Motor cables must be shielded as they otherwise act as an antenna.
Unshielded cables could cause interference in the surrounding area. If uncertain, the shield can be doubled; for further information, see FAULHABER accessories catalog and chap. 4.3.4, p. 47.
4. Are the contacts correctly screwed down or properly plugged in?
5. Are the cables laid in accordance with the standards/directives (e.g., IPC-A-620B-2013)?
 - a) Sensor cables and encoders are to be laid at least 10 cm from the motor phases.
 - b) Lay sensor cables at least 10 cm from all other signal cables that are not also sensor cables. Alternatively, use absolute encoders and/or line drivers.
 - c) Keep cables away from high-voltage current and mains cables.
 - d) Only cross cables at an angle of 90°.
6. Is it necessary to use filters?
 - a) Use filters in the case of poor signal quality or if interference occurs/is to be expected.
 - b) Note the product listing in chap. 4.3.5, p. 50.

Installation

Conformity measurements

The following points must be observed during the conformity measurement:

Conducted interference voltage measurement	Radiated interference voltage measurement
<ul style="list-style-type: none"> When laying cables, remove all loops. Lay the cables with a meandering shape. 	<ul style="list-style-type: none"> Where possible, lay cables over a grounding plate.
<ul style="list-style-type: none"> Connect the shield of the motor cable on the motor side and as close as possible on the controller side. The shield is to be connected over a large area, ideally with a round connection. 	<ul style="list-style-type: none"> The connection of the motor cable shield is to be as short as possible Keep the motor cable as short as possible.
<ul style="list-style-type: none"> Use an input filter. When selecting, pay attention to the difference of filter attenuation between 50 Ω and realistic values 1/100 Ω or 100/1 Ω measurement. 	<ul style="list-style-type: none"> Use a motor filter and keep the connection as short as possible.
<ul style="list-style-type: none"> If possible, secure cable with shield clamps or with adhesive tape. 	

Maintenance and diagnostics

5 Maintenance and diagnostics

5.1 Maintenance tasks

The drive is generally maintenance-free. Where the device is mounted in a cabinet, depending on the deposition of dust the air filter should be regularly checked and cleaned if necessary.

5.2 Diagnosis

Standard PCB and PCB with vertical plug connector

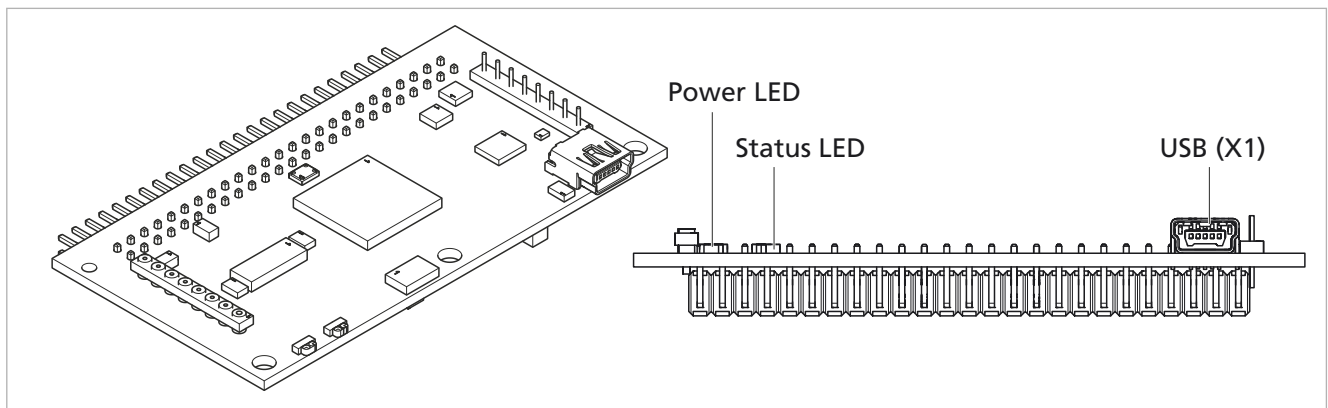

Fig. 40: Isometric (left) and front view (right) of the standard PCB

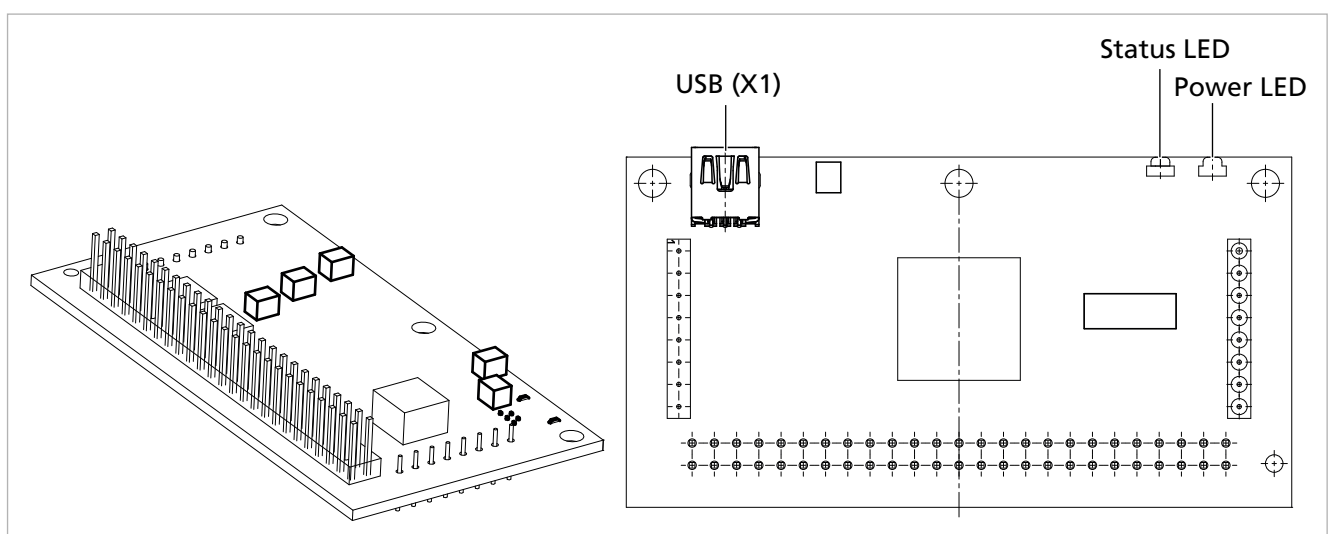

Fig. 41: Isometric view (left) and top view (right) of PCB with vertical plug connector

Maintenance and diagnostics

Tab. 35: LED overview

Designation	Function
State LED	<ul style="list-style-type: none"> Green (continuous light): Device active. Green (flashing): Device active. However the state machine has not yet reached the <i>Operation Enabled</i> state. Red (continuously flashing): The drive has switched to a fault state. The output stage will be switched off or has already been switched off. Red (error code): Booting has failed. Please contact FAULHABER Support.
Power LED	<ul style="list-style-type: none"> Green: Power supply within the permissible range. Off: Power supply out of the permissible range.

EtherCAT PCB

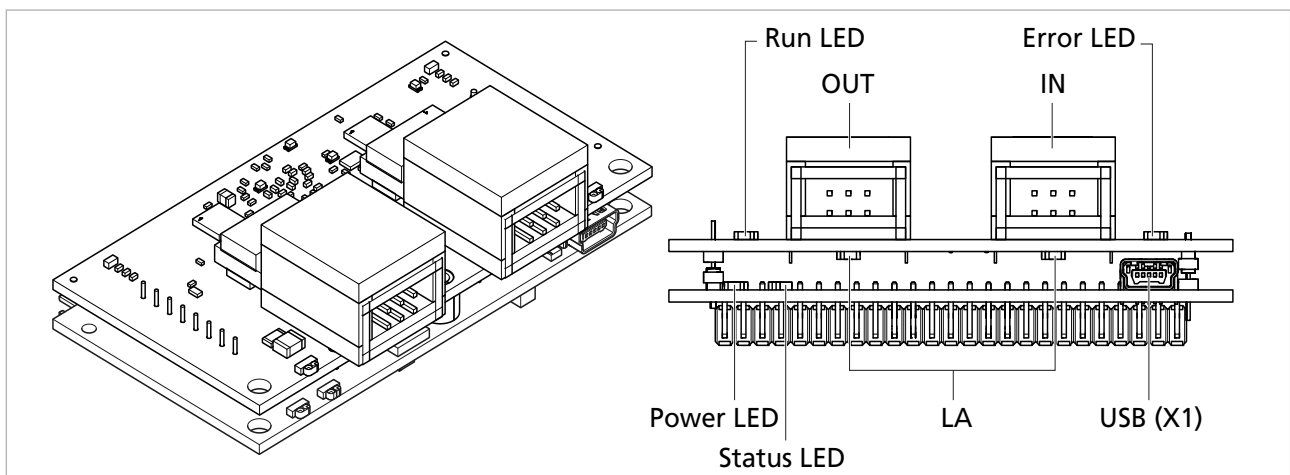

Fig. 42: Isometric (left) and front view (right) of the plugged-in EtherCAT PCB

Tab. 36: LED overview

Designation	Interface	Function
State LED	all	<ul style="list-style-type: none"> Green (continuous light): Device active. Green (flashing): Device active. However the state machine has not yet reached the <i>Operation Enabled</i> state. Red (continuously flashing): The drive has switched to a fault state. The output stage will be switched off or has already been switched off. Red (error code): Booting has failed. Please contact FAULHABER Support.
Power LED	all	<ul style="list-style-type: none"> Green: Power supply within the permissible range. Off: Power supply out of the permissible range.
RUN LED	EtherCAT	<ul style="list-style-type: none"> Green (continuous light): Connection present. Device is ready for use. Green (flashing): Device is in the <i>Pre-Operational</i>. state Green (single flash): Device is in the <i>Safe-Operational</i>. state Off: Device is in the <i>Initialisation</i> state.
ERR LED	EtherCAT	<ul style="list-style-type: none"> Red (flashing): Faulty configuration. Red (single flash): Local error. Red (double flash): Watchdog timeout. Off: No connection error
LA LED	EtherCAT	<ul style="list-style-type: none"> Green (continuous light): No data transfer. Connection to another participant established. Green (flashing): Data transfer active. Off: No data transfer. No connection to another participant.

Maintenance and diagnostics

5.3 Troubleshooting

If unexpected malfunctions occur during operation according to the intended use, please contact your support partner.

6 Accessories

Details of the following accessory parts can be found in the Accessories Manual:

- Connection cables
- Connectors
- Connector sets
- Installation aids
- Additional equipment

7 Warranty

Products of the company Dr. Fritz Faulhaber GmbH & Co. KG are produced using the most modern production methods and are subject to strict quality inspections. All sales and deliveries are performed exclusively on the basis of our General Conditions of Sale and Delivery which can be viewed on the FAULHABER home page www.faulhaber.com/gtc and downloaded from it.

Additional documents

8 Additional documents

8.1 Declaration of Conformity

EG–Konformitätserklärung **EC Declaration of Conformity**

Dokument-Nr./Monat.Jahr:
Document-No./Month. Year:

EG-00022-001 / 04.2021

Der Hersteller:
The manufacturer:

Dr. Fritz Faulhaber GmbH & Co. KG
Daimlerstr. 23/25
D-71101 Schönaich
Germany

erklärt hiermit, dass das folgende Produkt
declares that the following product

Produktbezeichnung:
Product designation:

MC5004 P RS/CO
MC5004 P ET

Produkttyp:
Product type:

Motorcontroller
Motor controller

den wesentlichen Schutzanforderungen entspricht, die in der/den nachfolgenden Richtlinie(n) festgelegt sind:
fulfills the essential protection requirements defined within the following directive:

EMV-Richtlinie 2014/30/EU
EMC-Directive 2014/30/EU

Die Einhaltung dieser Richtlinie(n) setzt die Umsetzung aller in der technischen Dokumentation genannten Maßnahmen voraus.

The measures indicated in all technical documents must be fulfilled in order to meet the requirements of this directive.

Diese Erklärung gilt für alle Exemplare, die in verschiedenen Leistungsdaten in dieser Serie hergestellt werden.
This statement should be valid for all derivatives produced according to the related construction drawings and electrical drawings, which are part of the technical documentation.

Die Konformität wird in Bezug auf folgende angewandte harmonisierte Normen erklärt:
The declared conformity relates to the following harmonized standards

- Anhang A / „Dokumentidentifikation“
- Annex A / Document identification

Die Anlage ist Bestandteil dieser Erklärung.
The annex is a component of this declaration.

Schönaich,

31.3.2021

(Datum)
(date)

Dr. Thomas Bertolini,
Geschäftsführung
(Name, Chairman)

(Unterschrift)
(signature)

Additional documents

Anhang A zur Konformitätserklärung *Annex A to Declaration of Conformity*

Dokument-Nr./Monat.Jahr:
Document-No./Month.Year:

EG-00022-001 / 04.2021

Die Übereinstimmung mit den genannten EG-Richtlinien wurde durch Überprüfung gemäß nach folgender Fachgrundnorm nachgewiesen:

The conformity with the EC guidelines was proven according to the following standards:

Fundstelle <i>Document</i>	Ausgabedatum <i>Date of issue</i>	Richtlinienbezug <i>Related to directive</i>
EN 61800-3	2018	EMV Richtlinie EMC directive

Additional documents

8.2 Declaration of Incorporation

**Einbauerklärung nach Anhang II B,
EG-Maschinenrichtlinie 2006/42/EG**
*Installation Declaration according to Appendix II B,
EC Machinery Directive 2006/42/EC*

Dokument-Nr./Monat.Jahr:
Document No./Month.Year:

EG-00023-001 / 04.2021

Der Hersteller:
The manufacturer:

Dr. Fritz Faulhaber GmbH & Co. KG
Daimlerstr. 23/25
D-71101 Schönaich
Germany

erklärt hiermit, dass es sich beim nachfolgend bezeichneten Produkt um eine Einbaukomponente (siehe unten) handelt und diese zum Einbau in eine Maschine bestimmt ist. Die Inbetriebnahme dieser unvollständigen Maschine ist solange untersagt, bis festgestellt wurde, dass die Gesamtmaschine, in die diese Komponente eingebaut werden soll, den grundlegenden Schutzanforderungen der hier genannten EG-Maschinenrichtlinie 2006/42/EG entspricht.

herewith declares that the product designated below is an installable component (see below), and that it is intended for installation in a machine. It is prohibited to bring this incomplete machine into service until it has been proven that the machine as a whole in which this component is to be installed meets the basic safety requirements of the here mentioned EC Machinery Directive 2006/42/EC.

Einbaukomponente:
Installable component::

MC5004 P RS/CO
MC5004 P ET

Produkttyp:
Product type:

Motion Controller (mit angeschlossenem Antrieb)
Motion Controller (with attached electrical drive)

Gemäß Anhang VII Teil B der EG-Maschinenrichtlinie 2006/42/EG wurden spezielle technischen Unterlagen für diese unvollständige Maschine erstellt. Durch begründetes Verlangen einzelstaatlicher Stellen können diese in elektronischer Form übermittelt werden.

Pursuant to Appendix VII, Part B of the EC Machinery Directive 2006/42/EC, specific technical documents have been created for this incomplete machine. On reasoned request by national authorities these documents may be transmitted in machine-readable format.

Der Bevollmächtigte für die Zusammenstellung und Übermittlung der relevanten technischen Unterlagen ist:
The person responsible for the compilation and transmission of the relevant technical documents is:

Dr. Andreas Wagener, Dr. Fritz Faulhaber GmbH & Co. KG, Daimlerstr. 23/25, 71101 Schönaich, Germany.

Schönaich, 31.3.2021
(Datum)
(Date)

Dr. Thomas Bertolini,
Geschäftsführung
(Name, Chairman)

(Unterschrift)
(Signature)

